

**CORPORATION OF THE TOWNSHIP OF ESQUIMALT
SUBDIVISION AND DEVELOPMENT CONTROL BYLAW**

SCHEDULE 'B'

REGIONAL SPECIFICATIONS - SEWERS AND DRAINS

INDEX

		<u>NO. OF PAGES</u>
A	ESQUIMALT EXCEPTIONS TO REGIONAL SPECIFICATIONS	1
B1	DESIGN DRAWINGS - PREPARATION.....	6
B2	"AS-BUILT" DRAWINGS	3
SD-1	DESIGN OF SEWERS AND DRAINS	5
SD-2	INSTALLATION OF SEWERS AND DRAINS	5
SD-1 TO SD-16	STANDARD DRAWINGS FOR SEWERS AND DRAINS.....	16
T-1	UTILITY TRENCH EXCAVATIONS BACKFILL AND CLEANUP	2
T-1	STANDARD DRAWING	1

CORPORATION OF THE TOWNSHIP OF ESQUIMALT
SUBDIVISION AND DEVELOPMENT CONTROL BYLAW
SCHEDULE 'B'
REGIONAL SPECIFICATIONS - SEWERS AND DRAINS

A. ESQUIMALT EXCEPTIONS TO REGIONAL SPECIFICATIONS

1.0 Introduction

1.01 Except as otherwise provided in this schedule, the Regional Municipal Specifications and Standard Drawings developed by Greater Victoria municipalities and dated July 1991 shall be followed in the design and construction of underground services.

2.0 Exceptions

2.01 Reference to water distribution system and water connection design and construction shall be exempted. Design and construction of water shall conform to City of Victoria requirements.

2.02 Mylar copies of as-built drawings specified in B2, 2.01 are not required. In their place, a digital copy of the revised design drawings (as-built), in a current version of AutoCad, shall be supplied.

REGIONAL SPECIFICATION B 1

SPECIFICATION OF DESIGN DRAWINGS

1.0 Scope

1.01 This specification shall govern the preparation of all engineering drawings for design of services within the Municipality.

2.0 General

2.01 Any information received from the Municipality on existing services shall be used as a guide only. Verification of locations and elevations must be checked by actual survey. The Municipality takes no responsibility for the exactness of service information obtained from plates and drawings. Confirm underground locations with utility companies.

2.02 Vertical control shall be shown in metric geodetic datum (mean sea level 0). Bench mark numbers, locations and elevations can be obtained from the Municipality. The reference bench mark and elevation shall be shown on the design drawing. Elevations below 0 geodetic shall be hi-lighted

2.03 Show the elevation of all: iron pins, existing basement floors and, where the building site is less than 1m above the road level, any proposed basement floor elevation. This information and connection information may be in pencil at the design stage but shall be to inked standards for as-built drawing submission. For subdivisions, indicate by shading the potential building envelope and, where land is below the calculated minimum floor elevation, show elevations at corners of the envelope or show a centre of lot profile to determine the amount of fill required for building.

2.04 All existing statutory rights-of-way or easements and their permitted uses must be checked through the Land Titles Office and be shown lightly shaded on the design drawing. Registration numbers shall be shown.

2.05 All proposed rights-of-way for new services are to be shown as a dashed line. These shall be tied to the iron pin in each lot, together with their width, permitted use, and the note "acquire" or "proposed". Right-of-way documents shall be prepared as detailed in these specifications.

2.06 A north arrow, existing and proposed street names shall be shown on the design drawing. The north shall be generally orientated towards the top of the sheet.

2.07 All services shall generally be shown on one plan with curbs (mountable or non-mountable), sidewalks, sewers, drains, gas, water, and underground wiring and poles identified as MC or NMC, S/W, S, D, G, W, and U/G, H or T respectively. Other services shall be clearly designated on the drawing.

REGIONAL SPECIFICATION B 1

- 2.08 Existing watermains, sanitary sewer mains, storm drains (including all appurtenances), ditches, pavement, curbs, sidewalks, underground wiring, gas, poles, trees, service connections and other underground utilities shall be indicated in plan and profile where applicable.
- 2.09 All proposed utilities shall be fully dimensioned as specified.

3.0 Drawing Information

- 3.01 Standard sheet size is A1 metric size 594mm x 841mm.
- 3.02 Use transparent plan/profile paper complete with standard Municipal title block in the lower part of the sheet. This paper may be purchased from the Municipality. Personalized Company plan/profile paper may be used provided it can meet the following requirements:
 - 1) Plan view shall be in the lower half of the page with Municipal title block added in the lowest 50 mm of the page.
 - 2) Profile view shall be 1 x 5 lines to the centimeter and occupy the upper half of the page.

The use of plan on one sheet and profile on a second sheet shall not be allowed.

- 3.03 Dimensioning of drawing shall be given from an existing or proposed iron pin or lot line.
- 3.04 Proposed construction shall shown as dashed lines and the existing shown as solid lines.
- 3.05 Lines and printing shall be in Leroy and be of uniform size using the following weights for: Lot lines #.25; Road lines #.5; Sewer, drain, water lines #.35. Construction notes shall be confined to a separate "note" column, wherever possible, with numbered references in plan or profile.
- 3.06 Road chainage shall be tied to an iron pin from the start of construction.

4.0 Scales

Normally:	Horizontal 1:500	Vertical 1:100 or 1:50
Details: *	Horizontal 1:200	Vertical 1:20 or 1:50
Cross Sections:	Horizontal 1:100	Vertical 1:100
Structural Details	1:20	

* e.g.: a detail of piping around two closely spaced manholes

5.0 Requirements for Subdivision Key Plan

- 5.01 A key plan, when required, shall be on the right side of the design drawing and shall include the following information:
- a) Plan of adjacent streets and existing lots with streets named and legals of adjacent lots given;
 - b) Civic address with the property being subdivided shown shaded;
 - c) North arrow;
 - d) The location of existing and proposed hydrants;
 - e) Contours at 1, 2 or 5 m intervals;
 - f) Title "Proposed Subdivision of (give the full legal) ";
 - g) If the subdivision is to be developed in stages, each proposed stage shall be clearly outlined and order of development indicated.
- 5.02 If a key plan is not required, the house number of existing houses shall be shown on the detailed design plan.

6.0 Requirements for Roads or Parking Areas

- 6.01 Show all iron pins adjacent to the works and the existing ground elevation at each pin or proposed pin.
- 6.02 Both plan and profile shall be tied to an iron pin, preferably near or at 0 + 0 chainage. If the chainage exceeds 120 m, a second tie shall be shown.
- 6.03 Show the road width, curb and sidewalk offsets measured from the property line.
- 6.04 Road profiles shall show gutter elevations. Except centre line profiles will be used where there are no curbs.
- 6.05 Detail the road construction with a cross sectional view of construction when circumstances require special consideration. In all cases the standard drawing section shall be referenced on the drawing.
- 6.06 The profile shall be shown at true centreline length and provided in as close relationship as possible to the plan.
- 6.07 Locate catch basins.
- 6.08 Locate barricades.
- 6.09 Locate ditches and centre of pavement in minimum road construction by offsetting to property line.

REGIONAL SPECIFICATION B 1

- 6.10 Existing and proposed critical driveway locations within the subdivision shall be shown as well as a profile of each driveway from the road centreline to the end of the driveway within the property.
- 6.11 Chainage of the BC and EC of horizontal curves shall be shown together with the internal angle, tangent length, arc and centreline radius. Curb radii shall be shown.
- 6.12 The percent grade to two decimal places shall be shown on the profile together with the following information on vertical curves:
- a) The chainage and elevations of BVC, EVC, and VPI;
 - b) The external value, e;
 - c) The length of vertical curve;
 - d) The elevation and chainage of the low spot of sag curves.
- 6.13 On superelevated curves and cul-de-sacs on vertical and horizontal curves, show a gutter profile (no centreline profile).



7.0 Requirements for Sewer and Drain

- 7.01 The following information shall be shown on the profile:
- a) Size, type, class of pipe, class of bedding;
 - b) Percent grades to two decimal places. If critical, mark "CR" after the grade, if not critical, show the minimum grade thus: (1.08% min.);
 - c) Invert elevations at both inlet and outlet of manholes;
 - d) Information on vertical curves as detailed in paragraph 6.12;
 - e) Existing utilities.
- 7.02 The following information shall be shown on the plan:
- a) Information on horizontal curves as detailed in paragraph 6.11;
 - b) Pipe offsets from property line;
 - c) The grade of the connection from the upper end to the drop to the main if other than two percent.

REGIONAL SPECIFICATION B 1

- 7.03 The following additional information shall also be shown on the appropriate part of the drawing:
- a) Letter sanitary sewer manholes and cleanouts;
 - b) Number storm drain manholes, cleanouts and silt traps;
 - c) Structural detail of all manholes not covered by Municipal Standard Drawings D-1, D-2, S-1, and S-2.

8.0 Requirements for Water

8.01 Drawings shall indicate whether the watermain passes over or under other underground utilities which it is crossing, shown ---- or ----

8.02 The following information shall be shown on the profile:

- a) The size, type and class of pipe, and class of bedding.
- b) For mains 200 mm and larger, profile grades to 2 decimal places.

8.03 The following information shall be shown on the plan:

- a) The offset of the main centreline from the property line.
- b) Where the short pipe lengths are required on curves, refer to Municipal Specification W-1, paragraph 3.11.
- c) Extent of work required of the Municipality in making the connection to the existing watermain.

9.0 Requirements for Other Utilities

9.01 Complete details of other utilities shall be obtained from the appropriate utility company.

9.02 The following information shall be shown on the plan:

- a) Existing utilities.
- b) Utility offset from property line and/or iron pin.
- c) Lot connections and other appurtenances.
- d) Existing and proposed poles shall be dimensioned from the pole road face to property line and/or pin.

9.03 Underground hydro, telephone and gas shall be shown schematically.

10.0 Requirements for Street Lighting

10.01 The following information shall be shown on the plan:

- a) Location of existing luminaires.
- b) Location, type and wattage of proposed luminaires.
- b) Line diagram and junction boxes.

11.0 Electronic Data Storage Systems

New section to be written.

AS-BUILT DRAWINGS

1.0 Scope

1.01 This specification governs as-built drawings of the following services: drains, sewers, water, gas, roads, curbs, lighting, sidewalks, underground power, telephone and cablevision, culverts, bridges, and other miscellaneous permanent structures.

2.0 General

2.01 As-built drawings shall consist of one paper print of the approved design drawing with changes or corrections made as required in Section 2.02. This shall be followed after approval by a mylar of the original design drawing, revised as required to show services as constructed.

2.02 The as-built drawings shall clearly show the location of all services as installed using offsets from survey pins. The extent shall be shown by inking the constructed service in the appropriate colour. The locations will be shown either by check-marking any original dimension on the drawing (if they are correct) or by showing the revised dimension beside the original dimension. In addition, the location to the end of underground pipe shall be shown.

Sanitary sewer	red
Storm drains and culverts	green
Water dark	blue
Gas	brown
Curb, sidewalk and road	orange
Lighting	pale blue
Underground - Power	purple
Telephone	purple
Cablevision	purple

2.03 Within two weeks of completion of water and within four weeks of completion of all other services to be installed by the Applicant, the Consulting Engineer shall deliver "as-built" drawings to the Municipal Engineer. These drawings shall include the following statement signed, sealed and dated by the Consulting Engineer:

"I certify that the following services (name them)

were inspected during construction and to the best of my knowledge, were installed in accordance with Municipal Specifications and Standard Drawings and as shown on this drawing."

3.0 Tolerances

- 3.1
- a) All horizontal dimensions shall be to the nearest 150 mm;
 - b) All vertical elevations to the nearest 3 mm except that ground elevations and service connection inverts at property line shall be to the nearest 30 mm;
 - c) Road horizontal locations shall be to the nearest 30 mm;
 - d) Road vertical locations shall be to the nearest 15 mm.

4.0 Additional Required Details

4.01 Drain and Sewer

- a) Location of rock cuts and hardpan requiring blasting, and depth of the rock excavation;
- b) The invert elevation at both inlet and outlet of manholes;
- c) Tie locations of manholes, cleanouts and other appurtenances to iron pins;
- d) Locate catch basin leads at the main by measurement from the centre of the downstream manhole;
- e) Locate service connections at property line showing distance from the nearest I.P. and at the main by chainage from the centre of the downstream manhole.
- f) Show ground and invert elevations of sewer and drain service connections at the property line or edge of right-of-way.

4.02 Water

- a) Show domestic water services and tie to corner iron pin;
- b) Location of rock cuts and maximum depth of rock excavation;
- c) Profile of main indicating numerically the invert at 15 m stations;
- d) Tie locations of fire hydrants to main valve and I.P.;
- e) Locate all valves and tie to iron pin.

REGIONAL SPECIFICATION B 2

- 4.03 Gas
- a) Locate rock cuts and maximum depth of rock excavation.
 - b) Locate valves, service connections, and other surface appurtenances, tied to iron pins.
 - c) Profile of main indicating numerically the invert at 15 m stations for mains 200 mm and larger.
- 4.04 Road, Curb and Sidewalk
- a) Locate end of curb, sidewalk and pavement.
- 4.05 Underground Power, Telephone and Cablevision
- a) Location and dimensions of service connections and all surface appurtenances, tied to iron pins.
- 4.06 Bridges, Etc.
- a) Location of structure;
 - b) Elevation of deck.
- 4.07 Lighting and Traffic Control
- a) Location of luminaires tied to an I.P.;
 - b) Line diagram;
 - c) Connection points to B.C Hydro and photo electric controllers.
- 4.08 New section for Electronic Data As-builts to be written.

REGIONAL SPECIFICATION S/D 1

DESIGN OF SANITARY SEWERS, STORM DRAINS AND SERVICE CONNECTIONS

1.0 Scope

1.01 This specification shall govern the design of all sewer and drain pipe and their appurtenances within the Municipality.

2.0 General

2.01 The Municipality reserves the right to make all connections or alterations to existing sanitary sewer and storm drain systems at the expense of the Applicant where it can be demonstrated that such works are necessary to accommodate the Applicant's development.

2.02 Upstream sewerage areas and other criteria required to accommodate upstream sewerage is normally specified.

2.03 Sanitary sewer design shall conform with the current "Guidelines for Assessing Sewerage Works" as prepared by the Ministry of the Environment of the Province of British Columbia.

2.04 In areas subject to excessive overland flows, or in seepage areas, french drains, diversion ditches, catch basins, etc. as required shall be installed and connected to acceptable outlets.

2.05 Only one single catch basin shall be connected to each 150 mm lead.

2.06 Catch basins shall be located in accordance with Regional Specification R-1 and installed in accordance with Regional Specifications R-2.

2.07 Discharge from commercial garages shall be intercepted by combination silt trap/grease interceptors prior to entering the Municipal storm drain system.

2.08 Open ditches shall enter an enclosed storm drain system through a silt trap.

2.09 Driveway culverts shall be a minimum 300 mm diameter and 6.0 m in length.

3.0 Drainage Design Criteria: Runoff Prediction

3.01 Upstream drainage areas and other criteria required to accommodate upstream drainage will be specified by the Municipal Engineer.

3.02 It shall be the responsibility of the Consulting Engineer to summarize drainage computations pertaining to that project on the standard forms provided by the Municipality and submit this data for approval together with a contour plan (scale 1:2500 where available) showing the drainage boundaries.

REGIONAL SPECIFICATION S/D 1

- 3.03 Subject to the approval of the Municipal Engineer, the principles of stormwater management - "zero increase in runoff" may be incorporated into the design of storm drains.
- 3.04 The recurrence interval used in designing storm drains up to and including 900 mm shall be ten years. Drains greater than 900 mm shall be designed to 25 years.
- 3.05 The intensity-duration curve to be used will be provided by the Municipality.
- 3.06 The following minimum values shall be used for the inlet time to the upstream end of nonextendable storm drain lines and for the coefficient of runoff (R)
- a) Unimproved areas, parks, playgrounds, cemeteries, etc - inlet time to be determined using standard engineering practice and $R = 0.35$.
 - b) Residential areas - low density, single family dwelling neighbourhoods - inlet time = 10 minutes and $R = 0.60$.
 - c) High density and largely impervious areas - inlet time = 5.0 minutes and $0.90 < R < 1.0$.

The above standards are minimum values only. Composite values based on percentages of different types of contributory areas may be established from the above figures. Future land use, as detailed in the Community Plan, shall be incorporated in the design.

4.0 Sewer and Drain Design Criteria: Pipe Capacity

- 4.01 Pipes shall be designed to carry the required design flow when flowing full except for pipes carrying flows less than that required for the minimum pipe size.
- 4.02 Pipe capacity shall be determined by the Manning Formula using the following roughness coefficients:
- $n = 0.013$ for concrete pipes
 - $n = 0.011$ for P.V.C. pipe.
- 4.03 The minimum grade for storm drains shall be that which produces a velocity of 0.9 metre per second in the pipe when flowing full.

The minimum grade of sanitary sewers shall be that which produces a minimum velocity of 0.61 metres per second in the pipe. However, a velocity of 0.9 metres per second must be obtained in the pipe above the last manhole of a non-extendable system.

REGIONAL SPECIFICATION S/D 1

- 4.04 Drain service connections for other than single family dwellings shall be sized according to the criteria contained in the B.C. Plumbing Code. Manholes shall be installed at the junction with the main line of all service connections greater than or equal to 200 mm in diameter.
- 4.05 Sewer service connections for other than single family dwellings shall be designed according to criteria contained herein for main lines.
- 4.06 Main sanitary sewer or storm drains shall not be less than 200 mm in diameter, except that sanitary sewers in the upper 360 m (total amount of upstream pipe) of a non-extendable system shall be 150 mm in diameter.

5.0 Materials

5.01 The following pipe is permitted for sanitary sewers and storm drains.

<u>Diameter</u>	<u>Material and Class</u>	<u>Use</u>	<u>Current Standard</u>
200mm to 900mm	Concrete - non reinforced class 3	main storm drains main sanitary sewers	ASTM C14
300mm to 3600	Concrete - reinforced	main storm drain Driveway culverts main sanitary sewers	ASTM C76
250mm and up	CMP (galvanized)	Driveway culverts	CGSB 34GP-96
150mm to 400mm	Ductile Iron - 1035 kPa	for main storm drains or catch basin leads main sanitary sewer	AWWA C151-76
100mm and 150mm	PVC Gravity Sewer Pipe DR 28, pipe stiffness of not less than 690 kPa with rubber gasket and integral bell.	100mm and 150mm for service connections 150mm for catch basin leads	CSA B182.1 ASTM D2412-73
200mm to 375mm	PVC Gravity Sewer Pipe DR 35, pipe stiffness of not less than 320 kPa with rubber gasket and integral bell	main storm drains 200mm for double catch basin leads main sanitary sewers	ASTM D3034- CSA B182.2 ASTM D2412-73
200mm to 1200mm	Ribbed PVC gravity sewer pipe with rubber gasket, pipe stiffness of not less than 320 kPa	main storm drains	CSA B182.4 ASTM F-794 UNI-B-9-82

6.0 Field Support Strength

- 6.01 The class and type of pipe and fittings, together with required class of bedding and trench widths shall be so selected that the pipe will support the anticipated gravity earth and any surface dead and live loads with a safety factor of 1.5.
- 6.02 Minimum cover for PVC pipe shall be 750 mm. For installation under areas used for vehicular traffic, minimum cover shall be 1.0 m.

Minimum cover for rigid pipe shall be 500 mm. For installation under areas used for vehicular traffic, minimum cover shall be 1.0 m., except for catch basin leads.

7.0 Alignment and Grade

- 7.01 Pipe lines shall normally be designed to follow a straight alignment and constant grade between manholes.
- 7.02 a) Curves will normally only be acceptable when a straight alignment and constant grade between manholes is not feasible.
- b) The radius of a horizontal curve shall be not less than 60 m, or that radius recommended by the pipe manufacturer, whichever is the greater.
- c) A vertical curve must not be less than 30 m in length. The curve must be designed so that the pipe deflection does not exceed the manufacturer's specifications.
- d) Only one curve, either horizontal or vertical, will be permitted between manholes, unless approved by the Municipal Engineer.

8.0 Location of Services

- 8.01 Sanitary sewers and storm drains should be located within the road allowance where possible. Service connections shall be installed to each proposed lot, connected to the main, and where feasible in a common trench with other services. Connections shall be made at right angles to the main within the frontage of the lot being served.
- 8.02 Service connections shall be extended to the edge of any right-of-way.
- 8.03 Where sanitary sewers or storm drains can be extended to accommodate future subdivisions upstream, the main shall be extended to the limits of the subdivision, and cleanouts installed at those locations.

9.0 Manholes and Cleanouts

9.01 The maximum distance between sanitary sewer and storm drain manholes may vary according to the pipe diameters as shown in the table below:

<u>Pipe Diameter</u>	<u>Maximum Spacing</u>
200 mm up to and including 375 mm	120 metres
400 mm up to and including 1200 mm	180 metres
over 1200 mm	300 metres

9.02 Manholes shall be provided at the following additional locations:

- a) At all changes of grade and/or alignment, except as provided in section 7.0 of this specification;
- b) At all changes of pipe size;
- c) At all pipe junctions other than service connections and catch basin leads. See 4.04 for exception..
- d) Where service connection is the same size as the main.

9.03 Drop manholes will be allowed only where particular circumstances preclude the use of normal manholes. These shall be constructed wherever the change in invert elevations through the manhole is greater than 600 mm. Allowance shall be made in the design for the effect of the resulting turbulence on the hydraulic capacity of the system.

9.04 The relative elevations entering and leaving a manhole are to be such as to ensure that the manhole does not reduce the hydraulic capacity of the system.

- a) Allowances for energy losses or changes in velocity are to be determined in accordance with sound hydraulic principles.
- b) Junctions will require special treatment as will all situations involving a pipe flowing into a smaller pipe at a steeper grade.

9.05 All manholes with pipes 450 mm or larger shall be individually designed.

9.06 Stubs shall be placed in manholes to allow for future connections. The length of the stubs shall be 600 mm maximum from the outside of the manhole. The end shall be securely capped.

9.07 Cleanouts shall be installed at the upstream end of all sanitary sewer and storm drain lines.

REGIONAL SPECIFICATION S/D 2

INSTALLATION OF SANITARY SEWERS, STORM DRAINS AND SERVICE CONNECTIONS

1.0 Scope

1.01 This specification shall govern the installation of all sanitary and storm drain pipe and their appurtenances within the Municipality.

2.0 General

2.01 Provision shall be made to maintain the flow of all drains, ditches, watercourses, and service connections which may be encountered with during the progress of the work. Where substandard systems are anticipated or located during construction, the substandard system shall be connected to the new installation or replaced. In every case the contractor and/or Consultant Engineer shall notify the Municipality when substandard systems are found. The contents of any sewer, drain or service connection shall not be allowed to flow into the trench or into the main. All offensive matter shall be immediately removed from the proximity of the work.

2.02 The Contractor shall ensure debris and mortar droppings do not enter any part of the sanitary sewer or storm drain system and shall leave all pipe lines, manholes, cleanouts, silt traps, catchbasins, and other appurtenances in a thoroughly clean condition.

3.0 Bedding

3.01 The class of bedding shall be as indicated on the approved design drawing.

3.02 All small diameter non-rigid (PVC) pipe to be provided with minimum Class B bedding compacted to 95% Standard Proctor Density.

3.03 All non-rigid (PVC) catch basin leads must be bedded according to the latest ASTM D 2321 Class II or better, compacted to 95%.

3.04 Ribbed PVC pipe must be bedded in accordance with the latest ASTM D2321, Class II or better.

4.0 Installation

4.01 Pipes shall be handled, stored and laid in accordance with the recommendations of the pipe manufacturer. In all cases gaskets shall be installed unless otherwise specified by the Municipal Engineer.

REGIONAL SPECIFICATION S/D 2

4.02 All pipe shall be laid to the designed grades and alignment within the following tolerances:

- a) Horizontal tolerance from true alignment shall not be greater than 60 mm from the designed location and the rate of deviation shall not exceed 40 mm in 10 m.
- b) Vertical tolerance from true grade shall not exceed the limitations as detailed in the table below:

<u>Grade</u>	<u>Maximum departure from design elevation</u>	<u>Maximum rate of deviation</u>
over 5%	30 mm	6 mm in 3 m
2% to 5%	15 mm	3 mm in 3 m
less than 2%	6 mm	3 mm in 3 m

4.03 Where a sanitary sewer is being constructed as an extension to an existing Municipal system, the end of the existing pipe shall remain sealed until the sewer extension is completed, flushed, tested and accepted by the Municipality. Upon acceptance, the seal may be removed and one length of pipe installed to connect the extension to the existing system.

4.04 Service connections over 26 m in length shall be provided with a buried cleanout every 26 m. A buried cleanout shall be provided when the service crosses a street boundary.

4.05 Where storm drains and sanitary sewers are installed in a common trench, there shall be a minimum 150 mm lateral clearance between the walls of adjacent pipes and between the walls of the pipes and the trench walls.

5.0 Manhole, Cleanout, Silt Trap and Catch Basin Construction

5.01 Manholes other than standard manholes shall be constructed as shown on the approved design drawings.

5.02 Cast-in-place manholes shall be allowed provided that the following criteria are observed:

- a) Concrete shall attain a minimum strength of 20 MPA at 28 days;
- b) Minimum wall thickness shall be 150 mm;
- c) Minimum internal dimensions shall be as detailed on Municipal Standard Drawings for standard manholes.

REGIONAL SPECIFICATION S/D 2

- 5.03 The manhole frames shall sit on at least one course of mortared concrete brick or approved alternate which shall be parged on both sides with a mortar paste composed of one part cement and three parts of sand and only sufficient water for workability.
- a) Grade adjustment of this type shall not exceed 250 mm. Bricks laid for adjustment shall be laid in headers.
- 5.04 Within the travelled portion of the road, heavy duty 200 mm frames and covers shall be installed on manholes, silt traps and cleanouts.
- 5.05 Within sewer or drain rights-of-way:
- a) Heavy duty 200 mm frames and covers shall be installed on manholes, silt traps and clean outs in travelled areas where it is known at the time of construction.
- b) Light duty 100 mm frames and covers shall be used in non-travelled areas.
- 5.06 All manholes and cleanouts not within the travelled portion of the road shall be set to finished landscaped elevation or 75 mm above existing grade if landscaped elevation is not available.
- 5.07 The area around a silt trap shall be graded so that surface runoff enters the gridded lid. The ditch sides and bottom around an inlet or outlet shall be rip-rapped for a minimum length of 1.5 m beyond the end of the pipe.

6.0 Testing

- 6.01 Sanitary Sewer pipe other than P.V.C. shall be tested at an average internal air pressure of 3.0 pounds per square inch greater than the back pressure of any ground water that may submerge the pipe. Ground water pressure shall be measured at the crown of the pipe at the lower end of the section under test. The maximum rate of air loss shall not be greater than 0.0030 cubic feet of free air per minute per square foot of internal pipe surface.

REGIONAL SPECIFICATION S/D 2

6.02 The requirements of paragraph 6.01 shall be considered satisfied if the time, in seconds, required for the pressure to a decrease of 3.5 pounds to 2.5 pounds per square inch greater than the back pressure of ground water as measured in paragraph 6.01 is not less than the allowable time calculated as follows:

- a) List diameters and lengths of all pipe under test.
- b) Calculate for $K = 0.011d^2 L$ where d = diameter of pipe in inches and L = length in feet of pipe of diameter "d".
- c) Calculate a value for $C = 0.0003882dL$ where d =diameter of pipe and L = length of pipe of diameter "d".
- d) Add all up to the values of K .
- e) Add up all the values of C .
- f) If the total of all C values is less than one, the total of all K values is the allowable time in seconds.
- g) If the total of all C values is greater than one, divide the total of all K values by the total of all C values. The result is the allowable time in seconds.

6.03 Alternate Tests - Sanitary Sewer

- a) Infiltration - The maximum allowable amount of infiltration from ground water or other sources into the section under test shall be 100 gallons per inch of pipe diameter per mile per 24 hours.
- b) Exfiltration - The maximum allowable amount of exfiltration from the section of sewer under test shall be a rate not greater than the manufacturer's specification for the pipe being tested.
- c) Modified Air Test - The test length shall be subjected to air pressure equivalent to a four-inch head of water. Leakage from the pipe shall be considered acceptable if, after disconnecting the air source, the pressure drop in five minutes is not more than a one-inch head of water.

REGIONAL SPECIFICATION S/D 2

6.04 Air Test for P.V.C. Sanitary Sewer Pipe

The air test shall conform to the procedures outlined in Uni-Bell Plastic Pipe Association "Handbook for P.V.C. Pipe" -Appendix Uni-B-6-79 or subsequent issues and is generally as follows:

The duration permitted for a prescribed low pressure air exfiltration pressure drop between two consecutive manholes shall be not less than that shown in Table A. The prescribed drop shall not exceed 0.5 psi from 3.5 to 3.0 psi in excess of the ground water pressure above the top of the sewer.

Table A

Minimum Duration for Air Test Pressure Drop

Pipe Size		Time
<u>Inches</u>	<u>mm</u>	<u>Minutes</u>
4	100	2 1/2
6	150	4
8	200	5
10	250	6 1/2
12	300	7 1/2
15	380	9 1/2

6.05 It is noted that the foregoing calculations are made using Imperial units of measurement.

6.06 The Consulting Engineer shall, at his direction, arrange for periodic compaction testing within the pipe zone where trenches are over one metre deep. Test results shall be submitted to the Municipal Engineer.

6.07 Video Camera inspection, Sanitary Sewer or Storm Drain

Prior to acceptance of any sewer or drain line, the Consulting Engineer shall arrange for a video camera inspection of the line. The recording tape shall be provided to the Municipal Engineer complete with the camera operator's written report. If any deviations from standards are noted, during the camera work, the work shall be repaired and re-tested.

Where blasting is required in proximity to existing mains, a video camera inspection of the existing main shall be required prior to and after blasting as detailed for new mains.

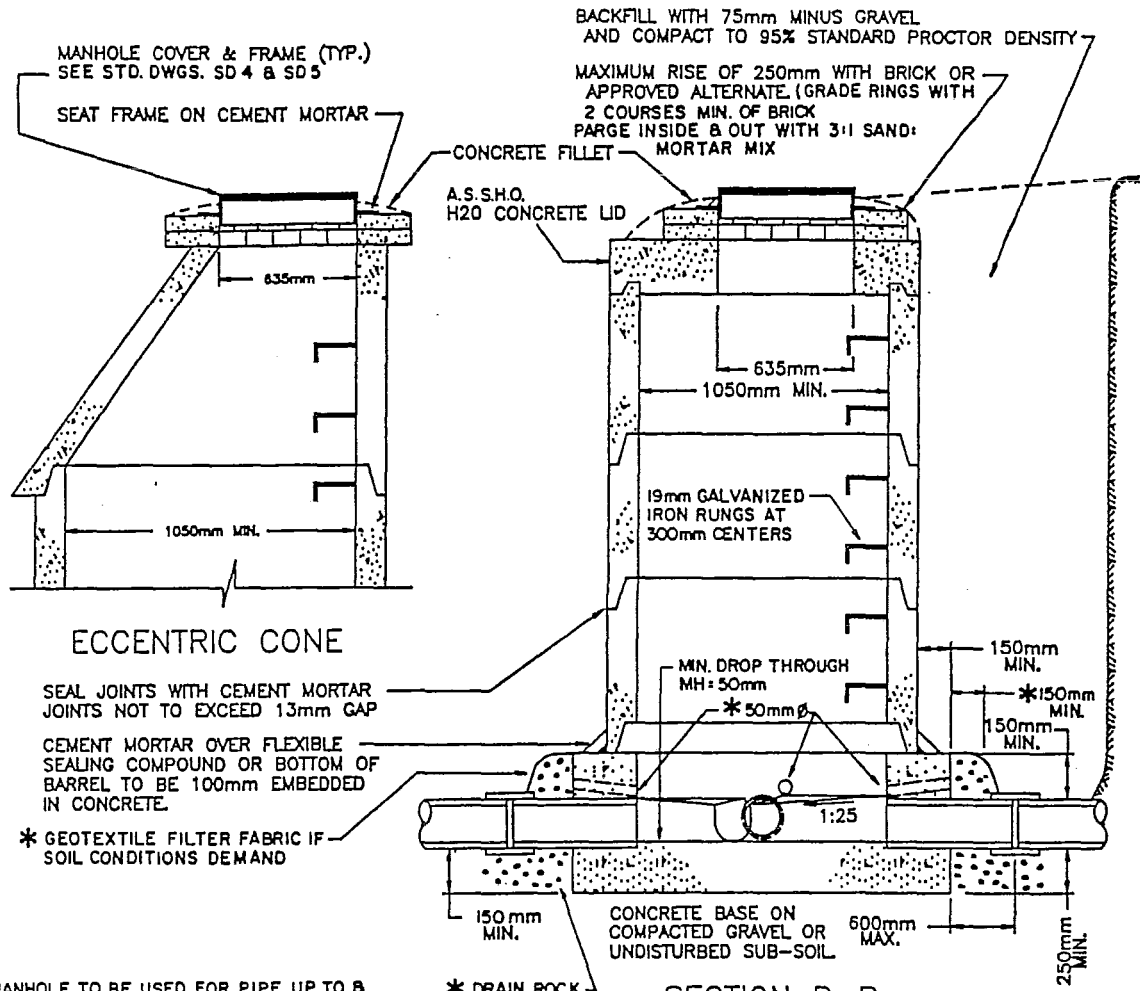

NOTES

1. STANDARD MANHOLE TO BE USED FOR PIPE UP TO & INCLUDING 375mm.
2. MIN. 150mm CONCRETE BELOW CHANNEL BASE. MANHOLE TO BE CONSTRUCTED ON COMPACTED GRAVEL OR UNDISTURBED SUB-SOIL SO THAT NO SETTLEMENT OCCURS.
3. TRIM PIPE ENDS FLUSH WITH INNER WALL OF MANHOLE.
4. SEWER MANHOLE TO BE WATERTIGHT.
5. PRECAST CONE OR LID & PIPE SECTIONS TO CURRENT A.S.T.M. C 478.
6. BRICK GRADE ADJUSTMENT TO BE LAID IN HEADERS.
7. FOR MANHOLE COVER & FRAME DETAILS SEE STD. DWGS. SD4 & SD5.
8. CAST-IN-PLACE CONCRETE, SEE SPEC. SD2, 5.02.
9. REINFORCEMENT TO BE SIZED & POSITIONED BY P.ENG.
10. VITREOUS PIPING - ALL JOINTS TO BE SLIP SEAL OR EQUAL.
11. CHANNELLING TO TOP OF PIPE TO CONSIST OF EITHER BOTTOM HALF OF PIPE PLUS VERTICAL WALLS OF CONCRETE OR ALL OF CONCRETE WITH SIMILAR X-SECTIONS.
12. CHANNELLING & BENCHING TO BE FINISHED TO TROWEL SMOOTHNESS.
13. R- RADIUS NOT TO BE LESS THAN 3 TIMES BRANCH PIPE DIAMETER.

* TRENCH DRAINAGE AT MANHOLES: FOR USE IN AREAS WITH HIGH WATER TABLES, EXCESSIVE GROUND WATER FLOW, OR TRENCHES THROUGH CLAY CUTS, BACKFILLED WITH FULL DEPTH GRAVEL.

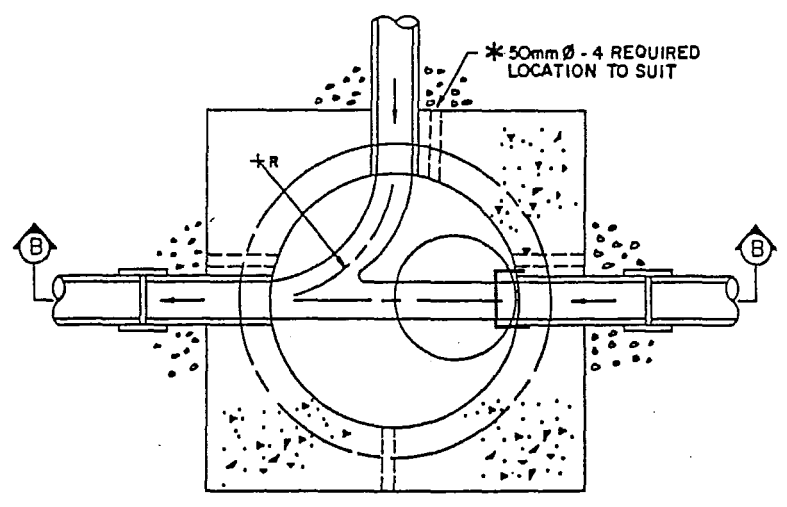

PLAN
* APPLICABLE TO DRAIN MANHOLES ONLY

REFER TO SPECIFICATIONS FOR FURTHER DETAILS

DATE	REVISIONS	APPROVED
------	-----------	----------

REGIONAL MUNICIPAL SPECIFICATION

STANDARD MANHOLE FOR UP TO & INCLUDING 375mm PIPE



STD. DWG. NO.

SD1

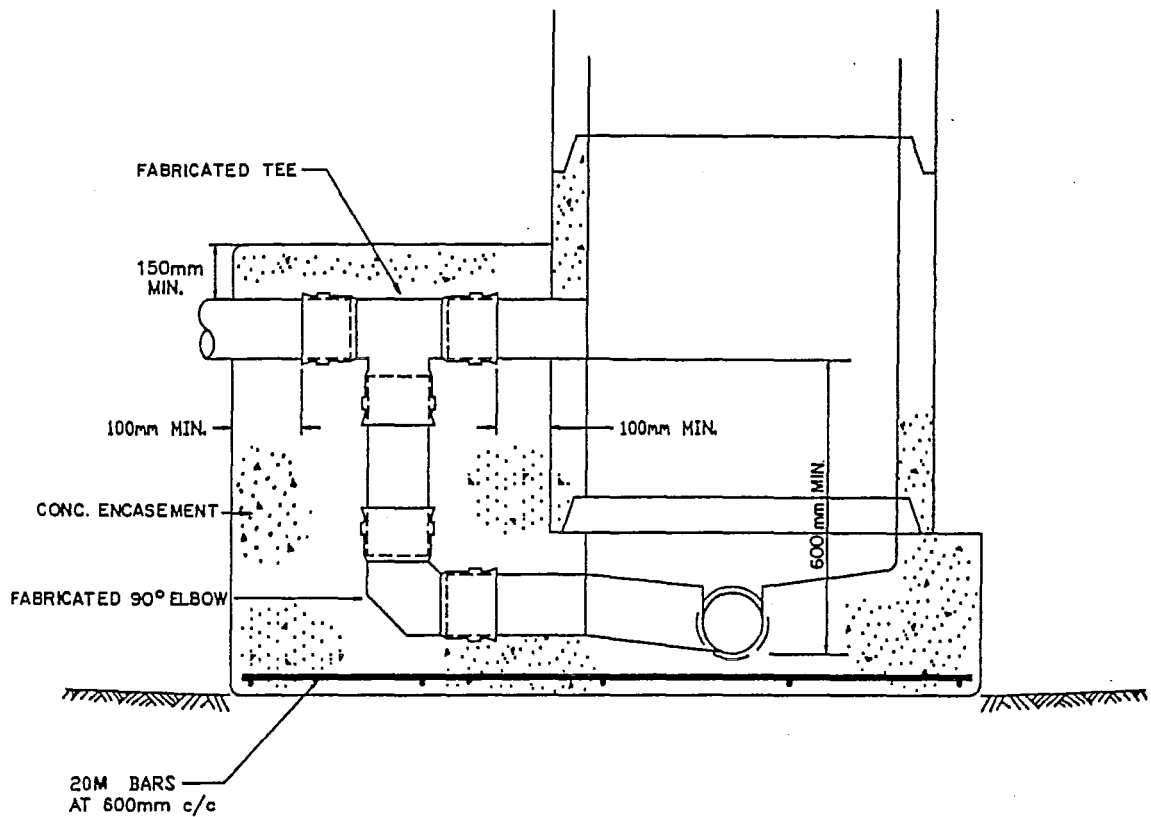

NOTES:

SEE STANDARD DRAWING NO. SD1 FOR TYPICAL MANHOLE DETAILS.

REFER TO SPECIFICATIONS FOR FURTHER DETAILS

DATE

REVISIONS

APPROVED

REGIONAL MUNICIPAL
SPECIFICATION

DROP MANHOLE



STD. DWG. NC

SD2

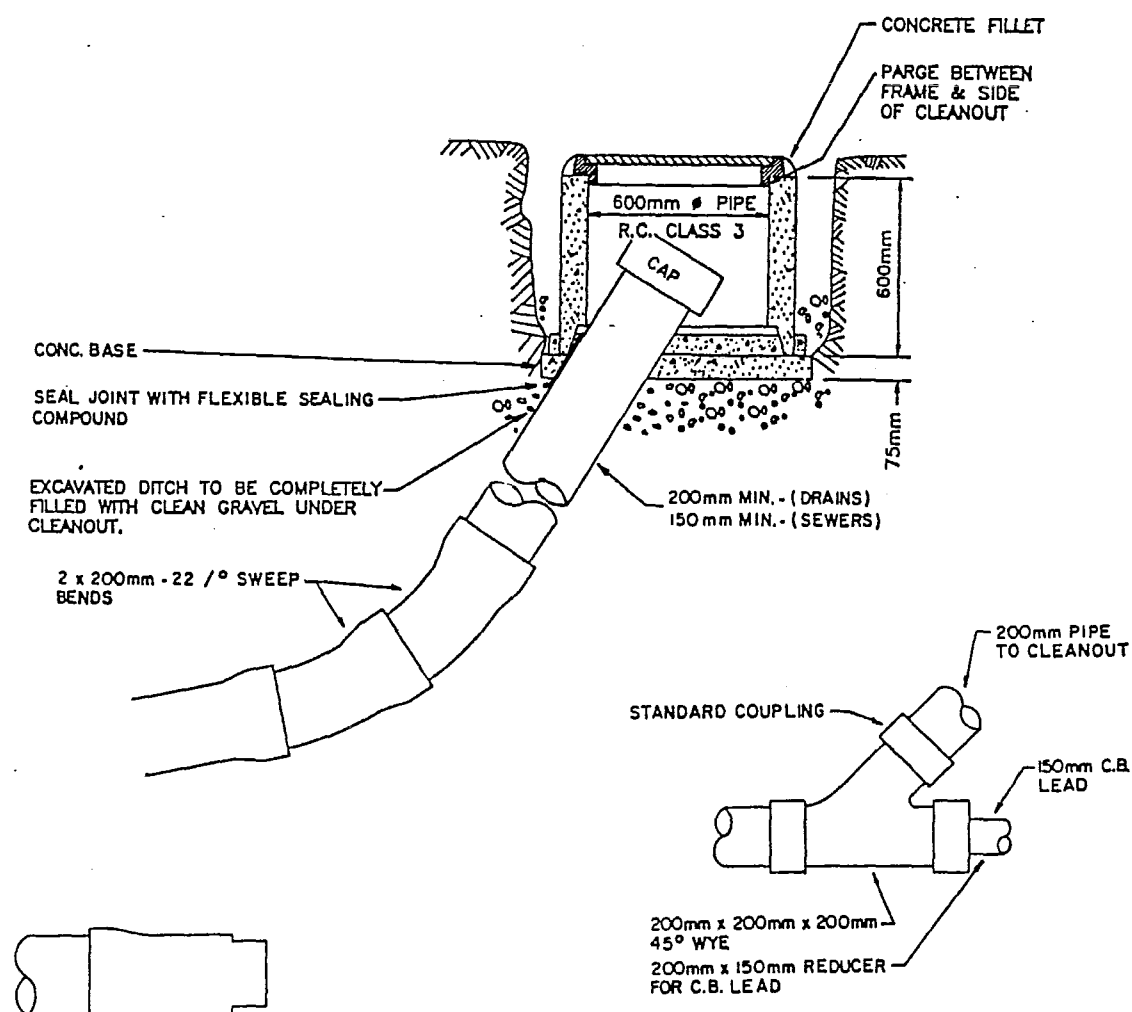

INCLUDE REDUCER IF DOWNSTREAM PIPE IS LARGER THAN 200mm.

RECOMMEND 'WYE' BE INCLUDED FOR USE BY 'C.B.' LEADS ONLY (NOT H.C.'S).

NOTES:

1. MANHOLE COVER AND FRAME: REFER TO STANDARD DWGS. SD 4 & SD 5.
2. TOP OF COVER TO BE 75mm \pm ABOVE EXISTING GROUND ON EASEMENTS OR BOULEVARDS WITH SOIL PLACED SLOPING AWAY FROM THE COVER.
3. TOP OF THE COVER TO BE FLUSH WITH THE SURFACE WHEN INSTALLED WITHIN TRAVELLED PORTION OF THE ROAD.
4. BACKFILL WITH CLEAN GRAVEL AND COMPACT.
5. CAP TO BE INSTALLED WITHOUT GASKET.

REFER TO SPECIFICATIONS FOR FURTHER DETAILS

DATE	REVISIONS	APPROVED
------	-----------	----------

REGIONAL MUNICIPAL SPECIFICATION

CLEANOUT



STD. DWG. NO

SD3

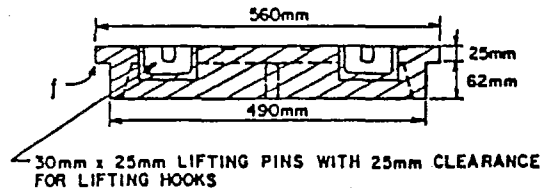
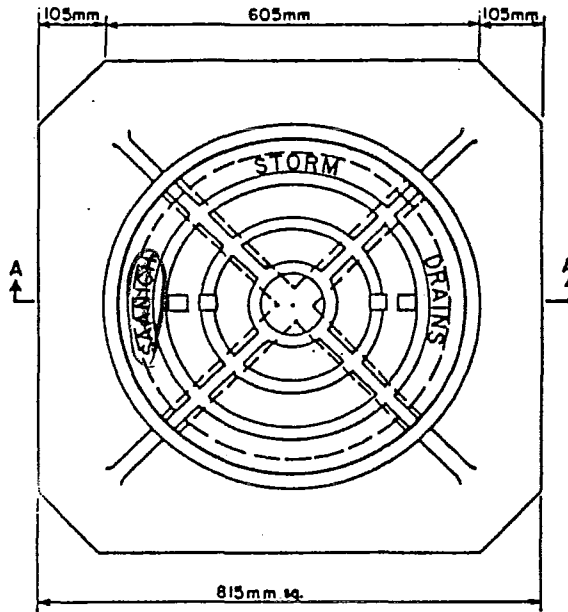

SECTION OF LID THROUGH A-A

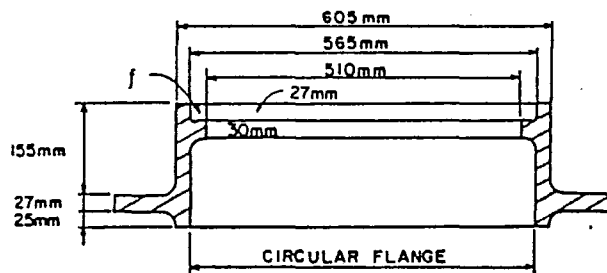

SECTION OF FRAME THROUGH A-A

HEAVY DUTY 100mm COVERS & FRAMES WILL BE ACCEPTED ON APPROVAL, WHERE 200mm SIZES DO NOT FIT.

NOTE: SEWER M.H.'S TO BE IDENTIFIED AS ~~SANITARY~~ SANITARY SEWERS"

Delete "Sanitich" SD4 SP5

REFER TO SPECIFICATIONS FOR FURTHER DETAILS

DATE	REVISIONS	APPROVED
------	-----------	----------

REGIONAL MUNICIPAL SPECIFICATION

200mm MANHOLE COVER & FRAME



STD. DWG. NO.

SD4

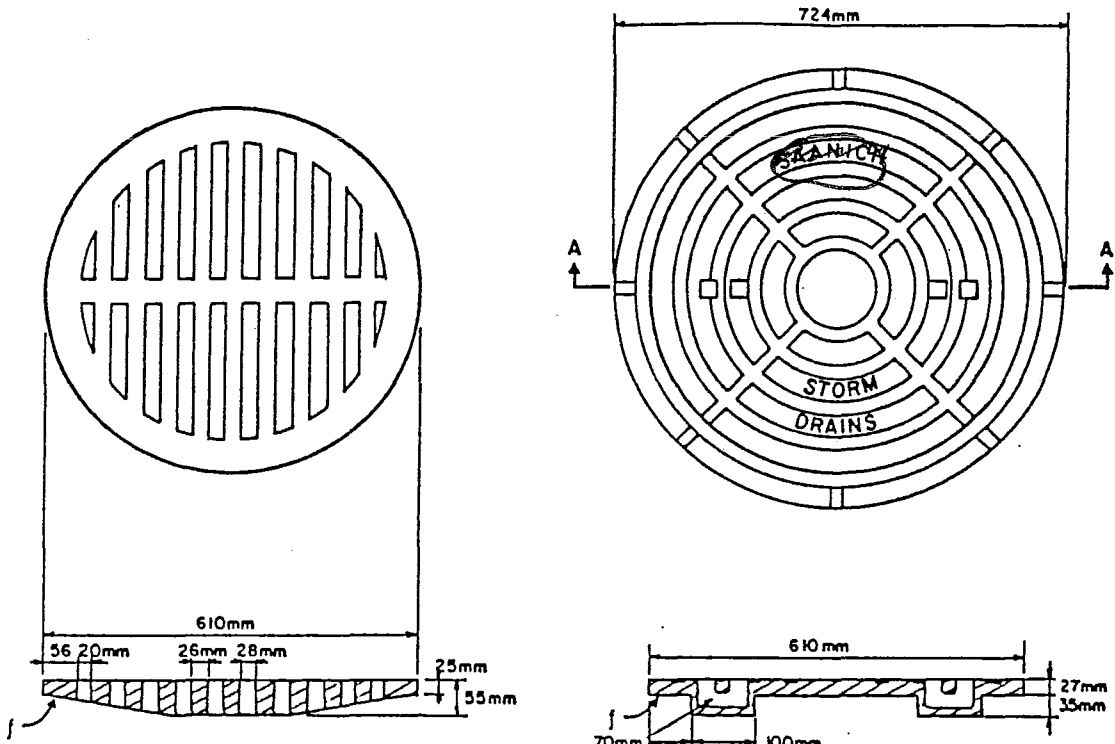

GRATED STORM DRAIN LID
(FOR USE WITH SILT TRAPS)

SECTION OF LID THROUGH A-A

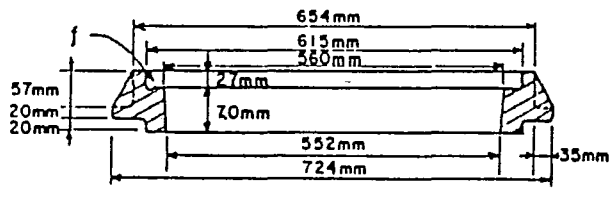

SECTION OF FRAME THROUGH A-A

NOTE: SEWER M.H.'S TO BE IDENTIFIED AS ~~SEWERS~~ SANITARY SEWERS"

REFER TO SPECIFICATIONS FOR FUTURE DETAILS

DATE	REVISIONS	APPROVED
------	-----------	----------

REGIONAL MUNICIPAL SPECIFICATION

100mm MANHOLE COVER & FRAME



STD. DWG. NO

SD5

50mm X 100mm STAKE ON PROPERTY LINE TO EXTEND FROM END OF CONNECTION TO 0.3m ± ABOVE GROUND LEVEL. WRAP AND TIE #14 WIRE ON HOUSE CONNECTION BRINGING LOOSE END OF WIRE TO SURFACE AND ATTACHING TO NAIL IN STAKE. STAKE TO BE PAINTED GREEN FOR DRAIN CONNECTIONS & RED FOR SEWER CONNECTIONS. STAKE MARKED TO SHOW DISTANCE FROM NAIL TO INVERT.

UPPER END OF BEND TO BE NO LOWER THAN TOP OF MAIN PIPE

* 100mm (MIN.) at 2% MIN. GRADE TO PROPERTY LINE OR EDGE OF R.O.W.

REFER TO STANDARD DRAWING SD7 FOR CONNECTION DETAILS

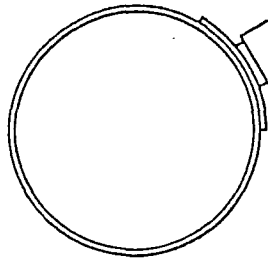

TYPICAL HOUSE CONNECTION

USE LONGSWEEP BENDS HORIZONTALLY OR VERTICALLY AS REQUIRED TO MEET ALIGNMENT OF STRAIGHT PORTION OF HOUSE CONNECTION.

HOUSE CONNECTION TO BE ATTACHED TO MAIN BY 'TEE', 'WYE' OR SADDLE FITTINGS.

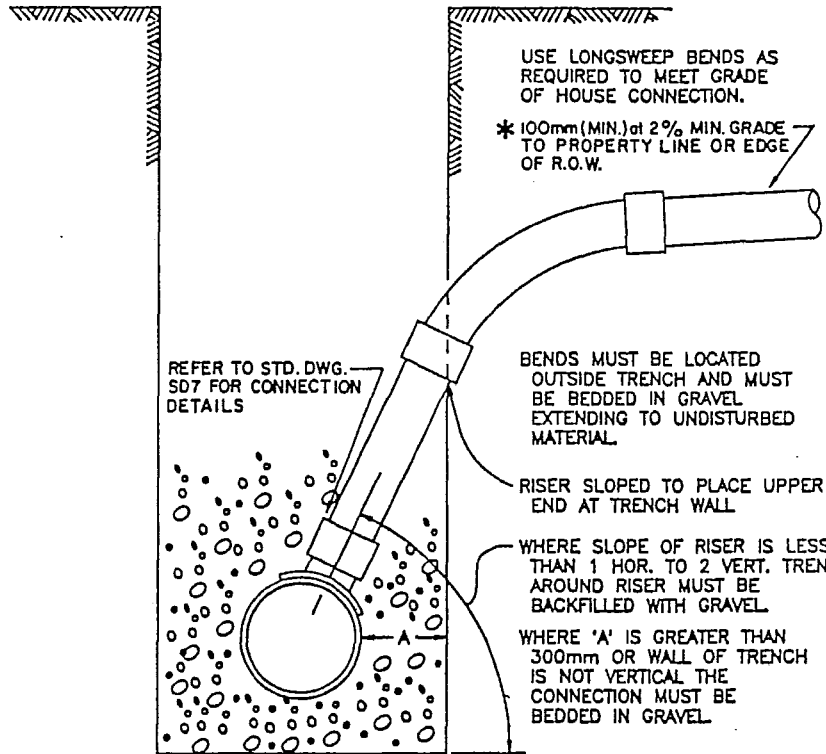

CONNECTION IN A DEEP TRENCH

USE LONGSWEEP BENDS AS REQUIRED TO MEET GRADE OF HOUSE CONNECTION.

* 100mm (MIN.) at 2% MIN. GRADE TO PROPERTY LINE OR EDGE OF R.O.W.

REFER TO STD. DWG. SD7 FOR CONNECTION DETAILS

BENDS MUST BE LOCATED OUTSIDE TRENCH AND MUST BE BEDDED IN GRAVEL EXTENDING TO UNDISTURBED MATERIAL.

RISER SLOPED TO PLACE UPPER END AT TRENCH WALL

WHERE SLOPE OF RISER IS LESS THAN 1 HOR. TO 2 VERT. TRENCH AROUND RISER MUST BE BACKFILLED WITH GRAVEL.

WHERE 'A' IS GREATER THAN 300mm OR WALL OF TRENCH IS NOT VERTICAL THE CONNECTION MUST BE BEDDED IN GRAVEL.

*FOR CONNECTIONS OTHER THAN SINGLE FAMILY DWELLINGS, SIZE ACCORDING TO B.C. PLUMBING CODE.

REFER TO SPECIFICATIONS FOR FURTHER DETAILS

DATE	REVISIONS	APPROVED
------	-----------	----------

REGIONAL MUNICIPAL SPECIFICATION

GENERAL SERVICE CONNECTION DETAILS



STD. DWG. NO.

SD6

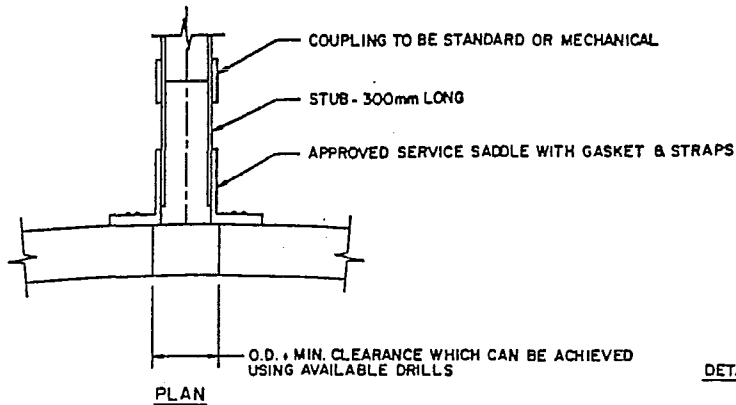

DETAIL OF SERVICE CONNECTION TO P.V.C. MAIN

NOTE: ALL HOLES IN MAIN TO BE CUT WITH APPROVED CUTTER. FOR SMALLER MAINS CONNECTION CAN BE MADE WITH APPROVED FABRICATED TEE OR WYE FITTINGS.

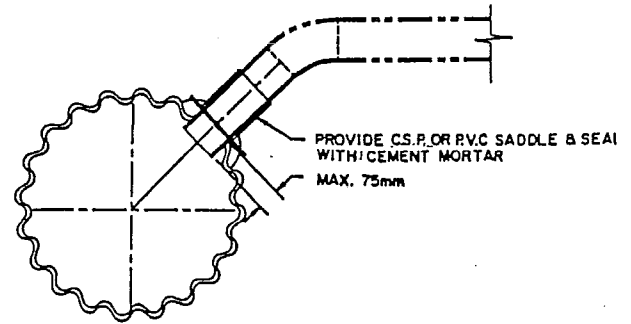

DETAIL OF SERVICE CONNECTION TO CORRUGATED STEEL OR RIBBED POLYETHYLENE PIPE
NOTE: SERVICE PIPE TO BE TRIMMED SO AS NOT OBSTRUCT FLOW IN MAIN

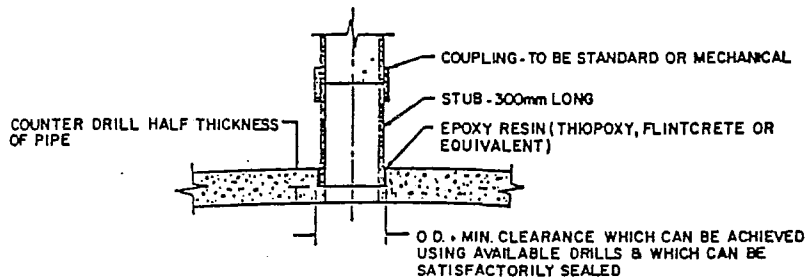

DETAIL OF LATERAL CONNECTION TO CONCRETE TRUNK

NOTE: ALL HOLES IN CONCRETE TRUNK TO BE DIAMOND DRILLED

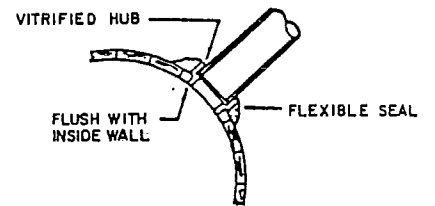

DETAIL OF LATERAL CONNECTION TO WOODSTAVE TRUNK

NOTES: ALL CUTS & ABRASIONS ON WOODSTAVE PIPE TO BE COATED WITH HOT CRESOTE

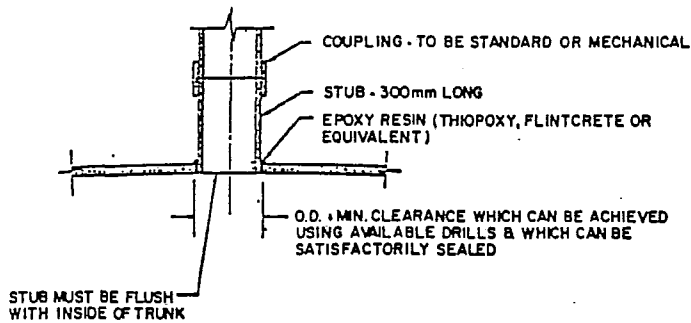

DETAIL OF LATERAL CONNECTION TO ASBESTOS-CEMENT TRUNK

NOTE: ALL HOLES IN ASBESTOS-CEMENT TRUNK TO BE DRILLED WITH PILOT A.C. CUTTER OR SIMILAR DEVICE

NOTE: FOR SMALLER DIA. MAINS, CONNECTION CAN BE MADE WITH APPROVED, FABRICATED TEE OR WYE FITTINGS

REFER TO SPECIFICATIONS FOR FURTHER DETAILS

DATE	REVISIONS	APPROVED

REGIONAL MUNICIPAL SPECIFICATION

SERVICE CONNECTION DETAILS



STD. DWG. NO

SD7

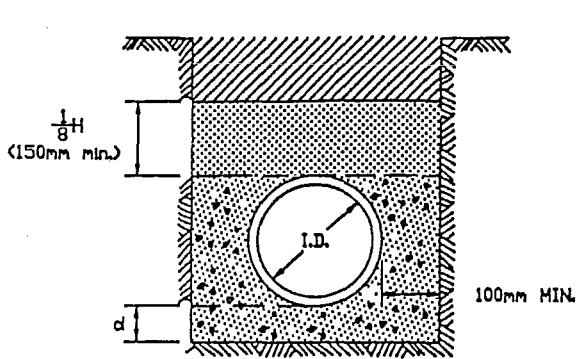

CLASS B
FIRST CLASS BEDDING
LOAD FACTOR 1.9

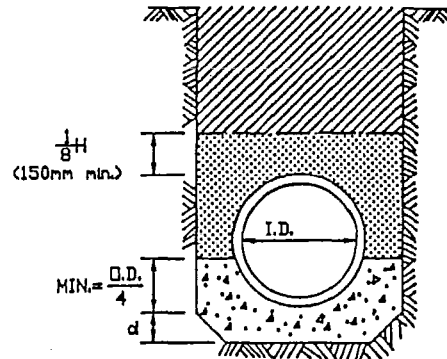

CLASS A
CONCRETE CRADLE
LOAD FACTOR 2.8
(RIGID PIPE ONLY)

DEPTH OF MATERIAL BELOW PIPE

I.D.	d(MIN.)
≤ 675mm	100mm
750mm - 1500mm	100mm
> 1500mm	150mm

O.D. -- OUTSIDE DIAMETER
 I.D. -- INSIDE DIAMETER
 H -- DISTANCE FROM GROUND TO TOP OF PIPE.



CONCRETE
 28 DAY STRENGTH TO BE 20 MPa OR MORE.



PIT-RUN GRAVEL (MINUS 25mm) OR SAND
 IN LAYERS NOT OVER 150mm AND COMPACTED BY SLICING WITH A SHOVEL OR TAMPING BAR.



HAND PLACED BACKFILL
 FINELY DIVIDED MATERIAL FREE FROM DEBRIS, STONES AND LARGE LUMPS.



MACHINE PLACED BACKFILL
 FREE FROM DEBRIS, LARGE LUMPS OR STONES OVER 150mm SIZE.

NOTES:

- UNDER SIDEWALKS, THE TRAVELLED PORTION OF THE ROAD & DRIVEWAYS, OR WITHIN 1.5m OF THE EDGE OF THE TRAVELLED ROAD, THE TRENCH WILL BE BACKFILLED WITH COMPACTED PIT-RUN GRAVEL OR EQUAL, TO WITHIN 300mm OF GROUND LEVEL. THE REMAINING 300mm TO BE BACKFILLED WITH ROAD GRAVEL.
- FOR ROCK OR OTHER INCOMPRESSIBLE MATERIALS, THE TRENCH SHOULD BE OVER-EXCAVATED A MIN. OF 150mm FROM THE OUTSIDE OF COUPLINGS OR BELLS OF THE PIPES AND REFILLED WITH GRANULAR MATERIAL. (MAX. AGGREGATE SIZE - 25mm)
- FOR P.V.C. PIPES, BEDDING TO BE COMPACTED TO A MINIMUM OF 95% STD. PROCTOR DENSITY WITHIN THE "HAUNCHING AREA".
- THIS SECTION SHOWS THE MIN. STANDARD, MANUFACTURER'S RECOMMENDED BEDDING & BACKFILLING SPECIFICATIONS WILL GOVERN.

REFER TO SPECIFICATIONS FOR FURTHER DETAILS

DATE

REVISIONS

APPROVED

REGIONAL MUNICIPAL
SPECIFICATION

CLASSES OF PIPE BEDDING



STD. DWG. NO.

SD8

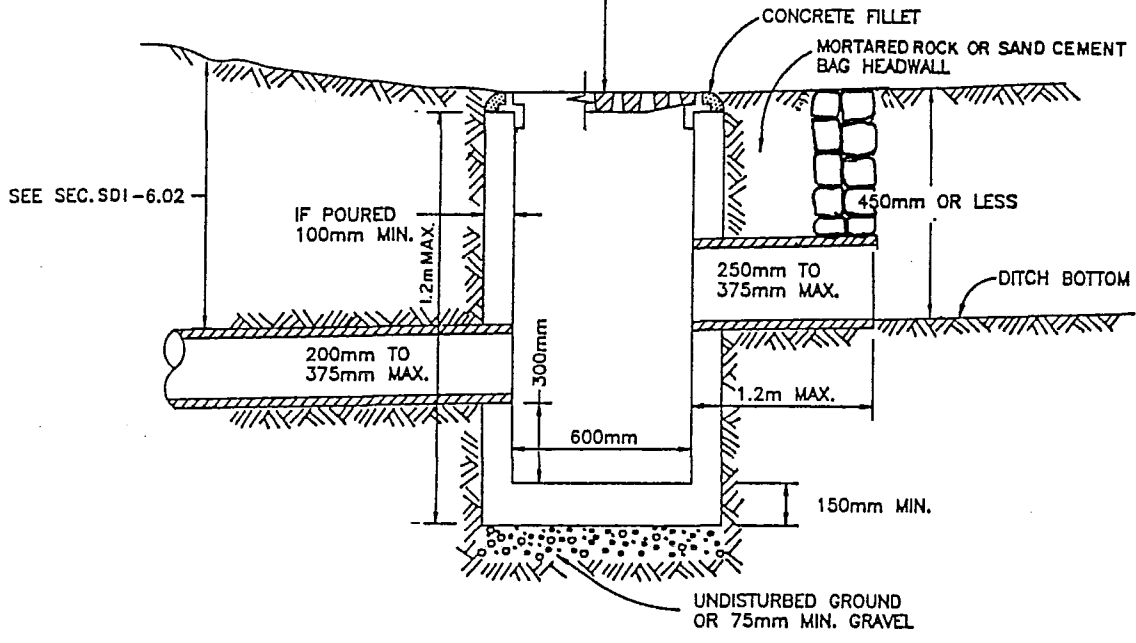
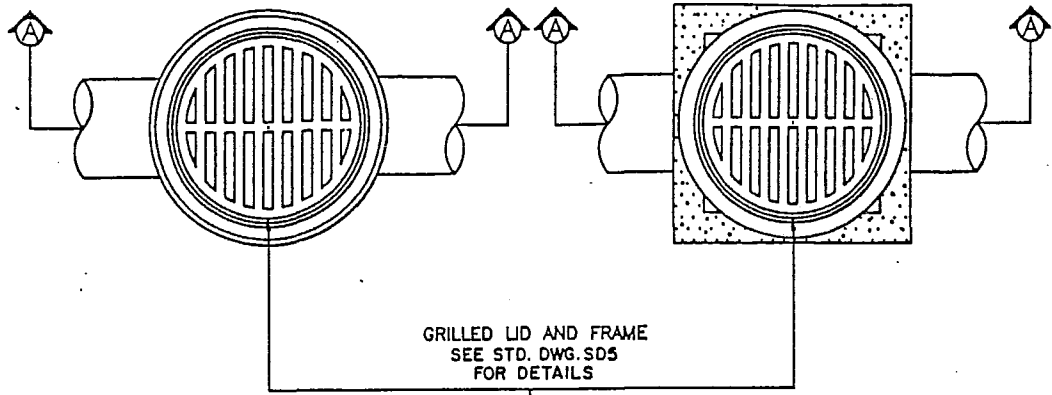

SECTION A-A

NOTES:

A 1.2m VERTICAL LENGTH OF 600mm III R.C. PIPE AS PER CURRENT ASTM C 76 SPECIFICATIONS SET ON END IS ACCEPTABLE IN LIEU OF MIN. 100mm THICKNESS OF POURED CONC. AS SHOWN.

FOR PIPES GREATER THAN 375mm, SPECIAL DESIGNED S.T.'S WITH OVERSIZED BARRELS WILL BE ACCEPTED.

TOP OF GRILL TO BE SET A MIN. OF 50mm BELOW SURROUNDING GROUND LEVEL.

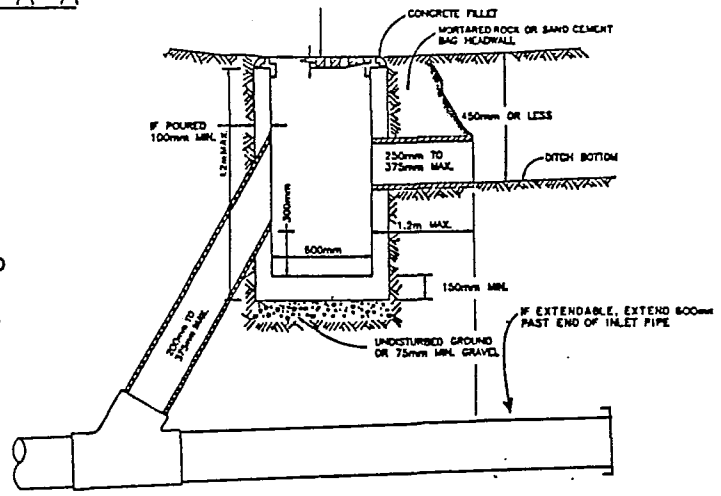

CONNECTION TO DEEP DRAIN

REFER TO SPECIFICATIONS FOR FURTHER DETAILS

DATE	REVISIONS	APPROVED

REGIONAL MUNICIPAL SPECIFICATION

SILT TRAP



STD. DWG. NO

SD9

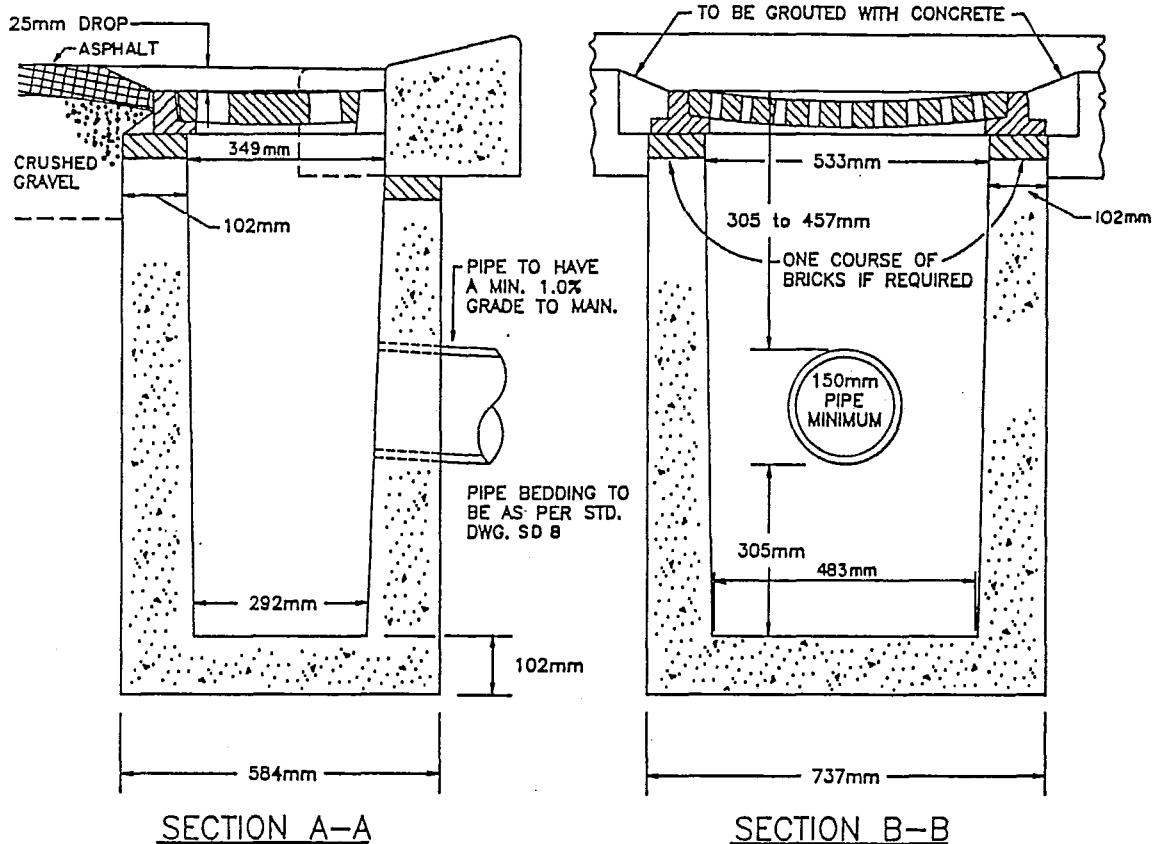
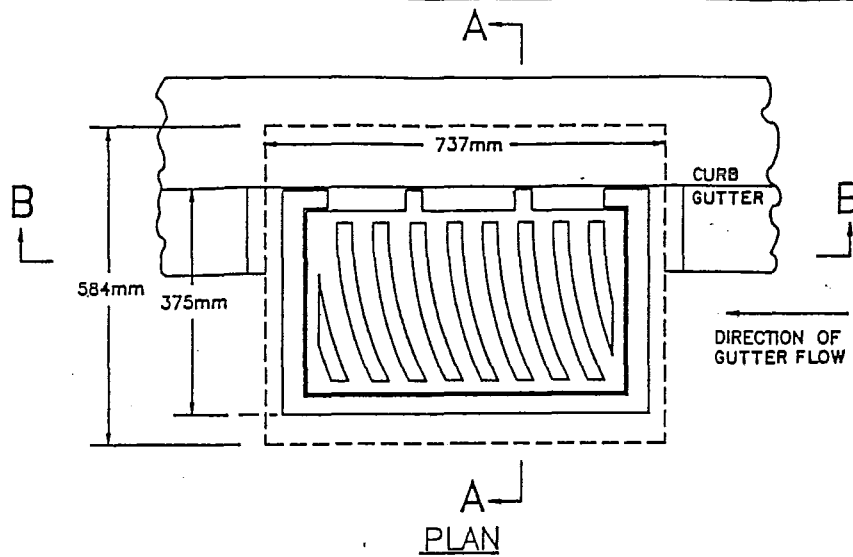

- NOTES:**
1. CATCH BASIN GRATE AND FRAME, SEE STD. DWG. SD13 FOR DETAILS.
 2. TRENCHES AND CATCH BASINS UNDER TRAVELLED PORTION OF THE ROAD TO BE BACKFILLED WITH GRAVEL AND COMPACTED AS PER SPECIFICATIONS.
 3. FOR DETAILS OF CURBS SEE STANDARD DRAWINGS R13, R13A, R14 & R15.
 4. BASE TO BE COMPACTED GRANULAR MATERIAL (98% STANDARD PROCTOR) OR CONCRETE SLURRY.

REFER TO SPECIFICATIONS FOR FURTHER DETAILS

DATE

REVISIONS

APPROVED

REGIONAL MUNICIPAL SPECIFICATION

RECTANGULAR CATCH BASIN
(FOR USE WITH CURB & GUTTER)



STD. DWG. NO.

SD10

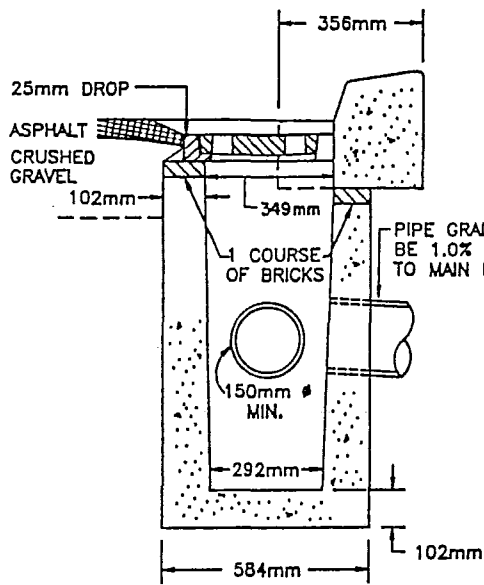
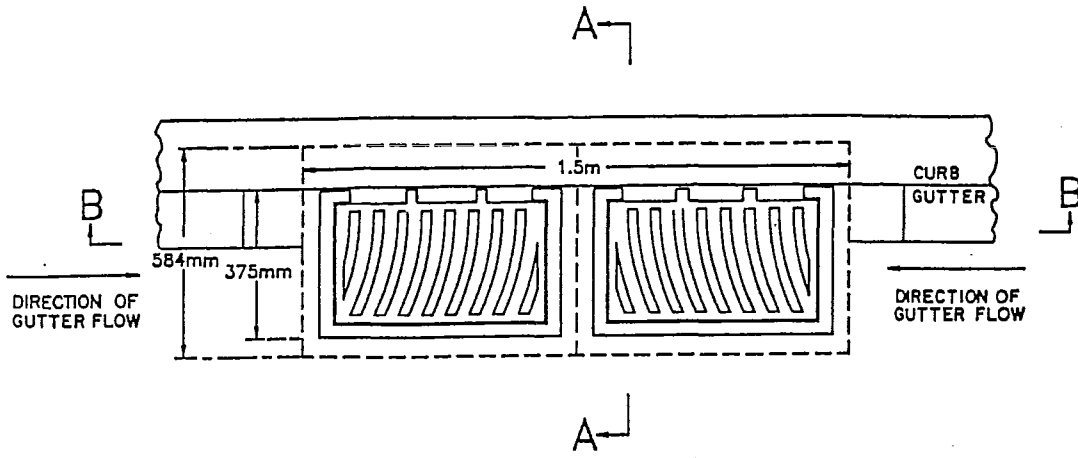

SECTION A-A

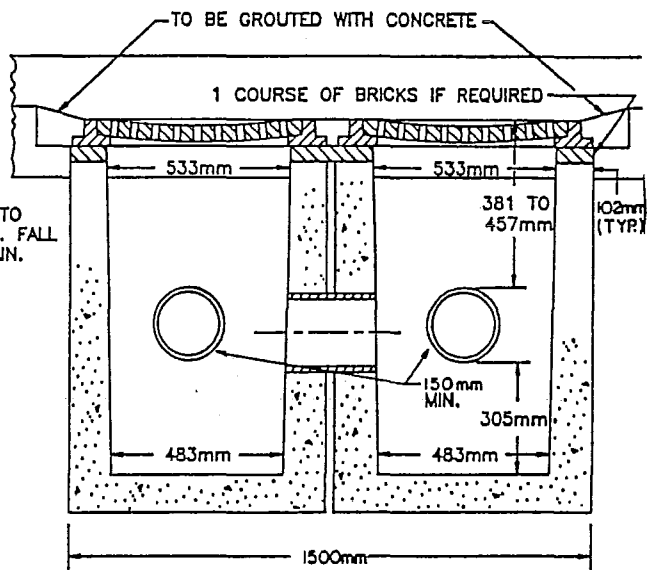

SECTION B-B

NOTES:

1. CATCH BASIN GRATE AND FRAME, SEE STD. DWG. SD13 FOR DETAILS.
2. TRENCHES UNDER TRAVELLED PORTION OF THE ROAD TO BE BACKFILLED WITH COMPACTED GRAVEL AS PER SPECIFICATIONS.
3. FOR DETAILS OF CURBS SEE DWGS. R13, R13A, R14 & R15.
4. BASE TO BE COMPACTED GRANULAR MATERIAL (98% STANDARD PROCTOR) OR CONCRETE SLURRY.
5. CATCH BASINS TO HAVE SEPARATE 150mm LEADS TO MAIN PLUS 150mm CONNECTION BETWEEN BASINS.

REFER TO SPECIFICATIONS FOR FURTHER DETAILS

DATE	REVISIONS	APPROVED

REGIONAL MUNICIPAL SPECIFICATION

DOUBLE CATCH BASIN (FOR USE WITH CURB & GUTTER)



STD. DWG. NO.

SD11

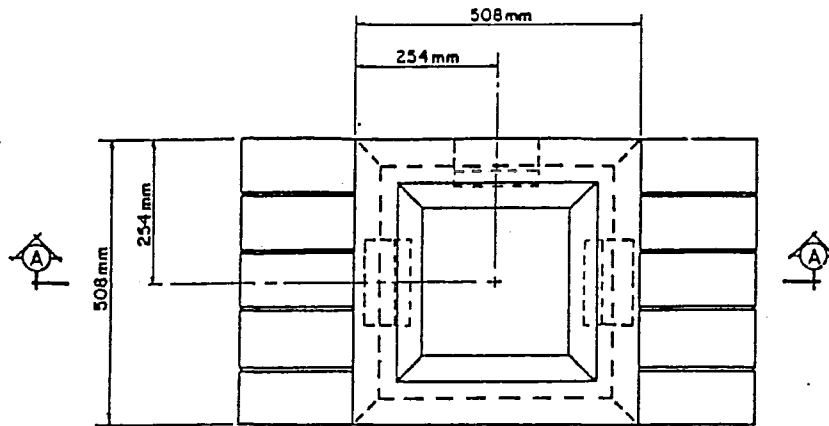

PLAN

To retain frame and grate use 11o3 courses of concrete bricks with 1:3 mortar. Typical on both sides of the catch basin.

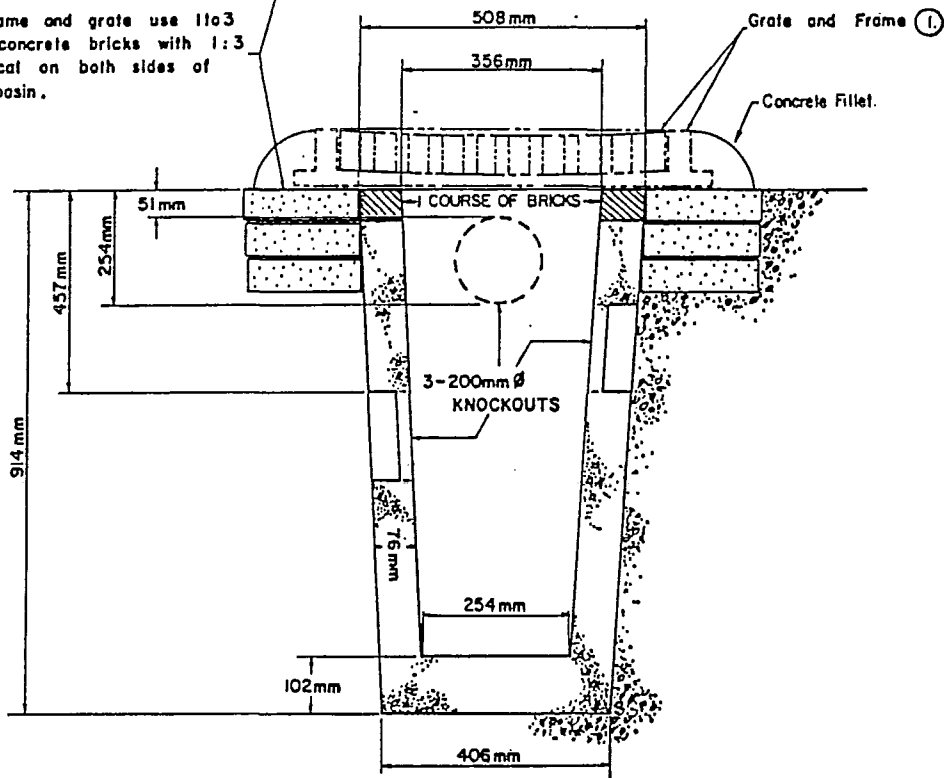

SECTION. A-A

NOTES

1. FOR DETAILS OF GRATES SEE STD. DWG. SD14.
2. FOR DETAILS OF CATCH BASINS TO DRAIN CURB & GUTTERED ROADWAYS SEE STD. DWG. SD10 & SD11.
3. BACKFILL TO BE COMPACTED GRAVEL.
4. FOR USE IN AREAS WITHOUT CURB & GUTTER.

REFER TO SPECIFICATIONS FOR FURTHER DETAILS

DATE	REVISIONS	APPROVED

REGIONAL MUNICIPAL SPECIFICATION

SQUARE CATCH BASIN



STD. DWG. NO.

SD12

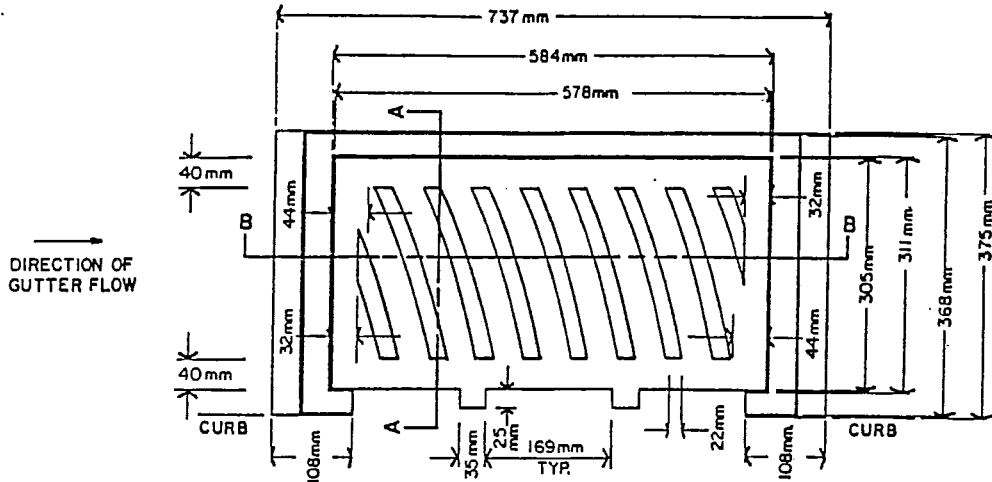

PLAN

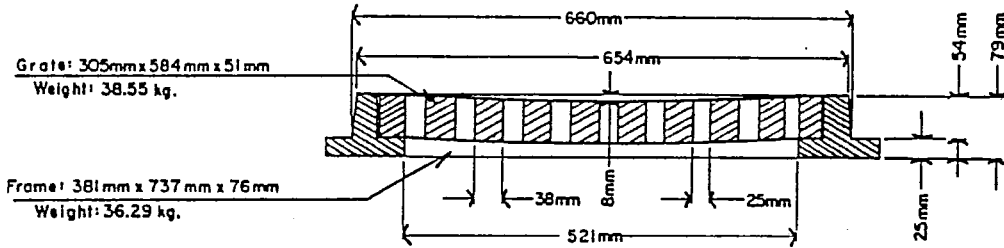

SECTION THROUGH B-B

NOTES

1. For use with catch basins in conjunction with curbs & gutters.
2. For details of catch basin see Std. Dwg. SD 10 & SD 11.

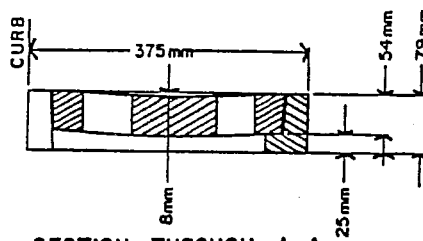

SECTION THROUGH A-A

MATERIAL: CAST IRON

REFER TO SPECIFICATIONS FOR FURTHER DETAILS

DATE

REVISIONS

APPROVED

REGIONAL MUNICIPAL
SPECIFICATION
RECTANGULAR CATCH BASIN
FRAME & GRATE



STD. DWG. NO.

SD13

PLAN

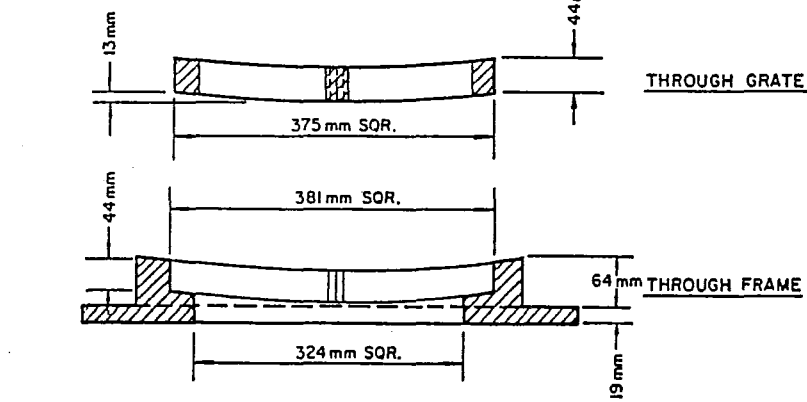
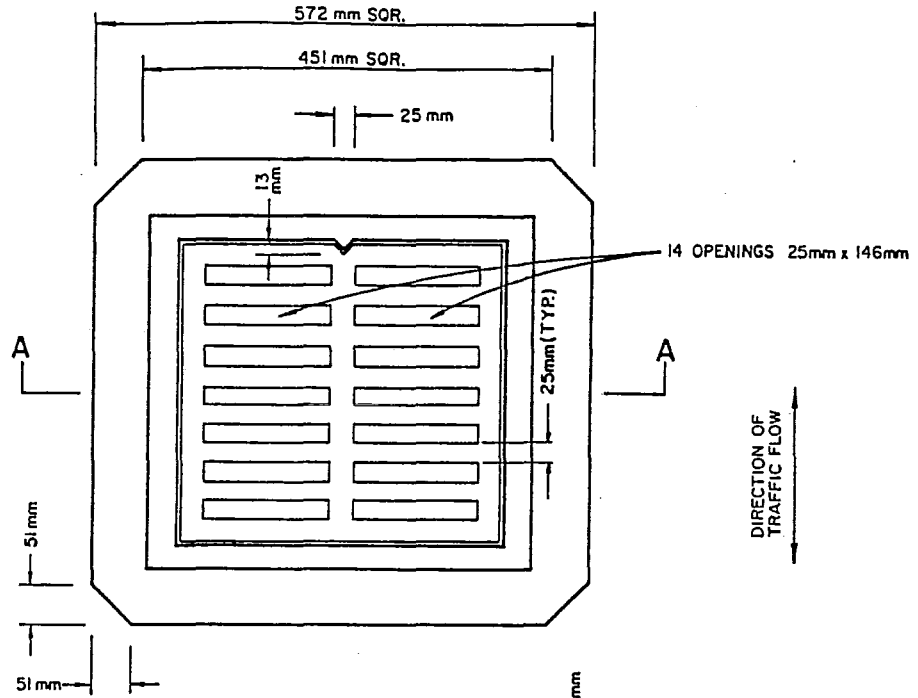

SECTION A-A

NOTES: FOR DETAILS OF CATCH BASIN, SEE STD DWG. SD 12
FOR USE IN AREAS WHERE CURB & GUTTERS NOT USED.

LONGITUDINAL AXIS OF GRATE OPENINGS TO BE PLACED
PERPENDICULAR TO THE DIRECTION OF TRAFFIC FLOW.

MATERIAL: CAST IRON

REFER TO SPECIFICATIONS FOR FURTHER DETAILS

DATE	REVISIONS	APPROVED
------	-----------	----------

REGIONAL MUNICIPAL
SPECIFICATION

SQUARE CATCH BASIN
FRAME & GRATE



STD. DWG. NO.

SD14

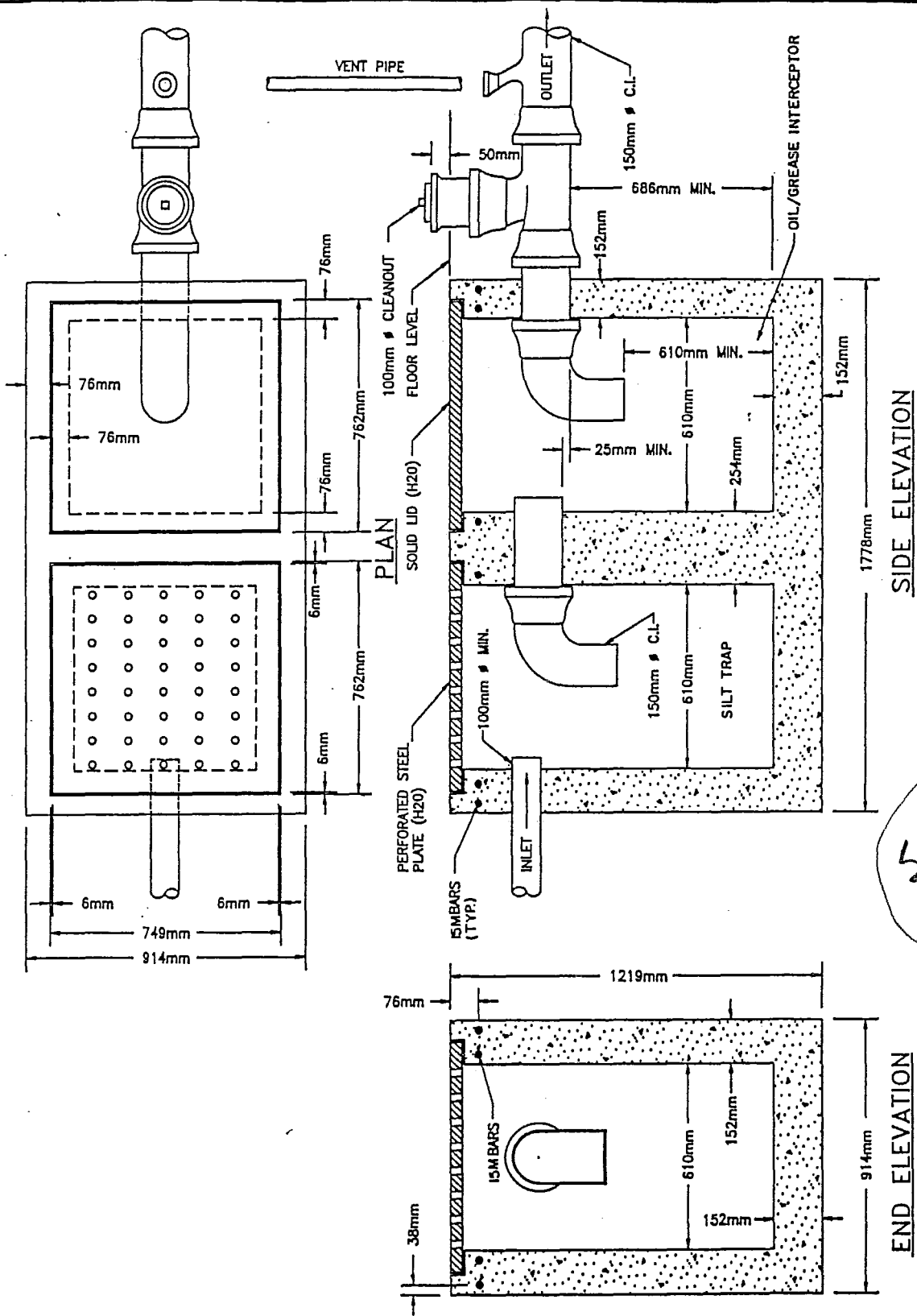

See New Issue 15504

REFER TO SPECIFICATIONS FOR FURTHER DETAILS

DATE	REVISIONS	APPROVED

REGIONAL MUNICIPAL SPECIFICATION
COMBINATION SILT TRAP & GREASE INTERCEPTORS FOR COMMERCIAL GARAGES



STD. DWG. NO.

SD15

REGIONAL MUNICIPAL SPECIFICATION

INTENSITY DURATION CURVE

REFER TO SPECIFICATIONS FOR FURTHER DETAILS

DATE

REVISIONS

APPROVED

STD. DWG. NO.

INTENSITY (mm/hr)

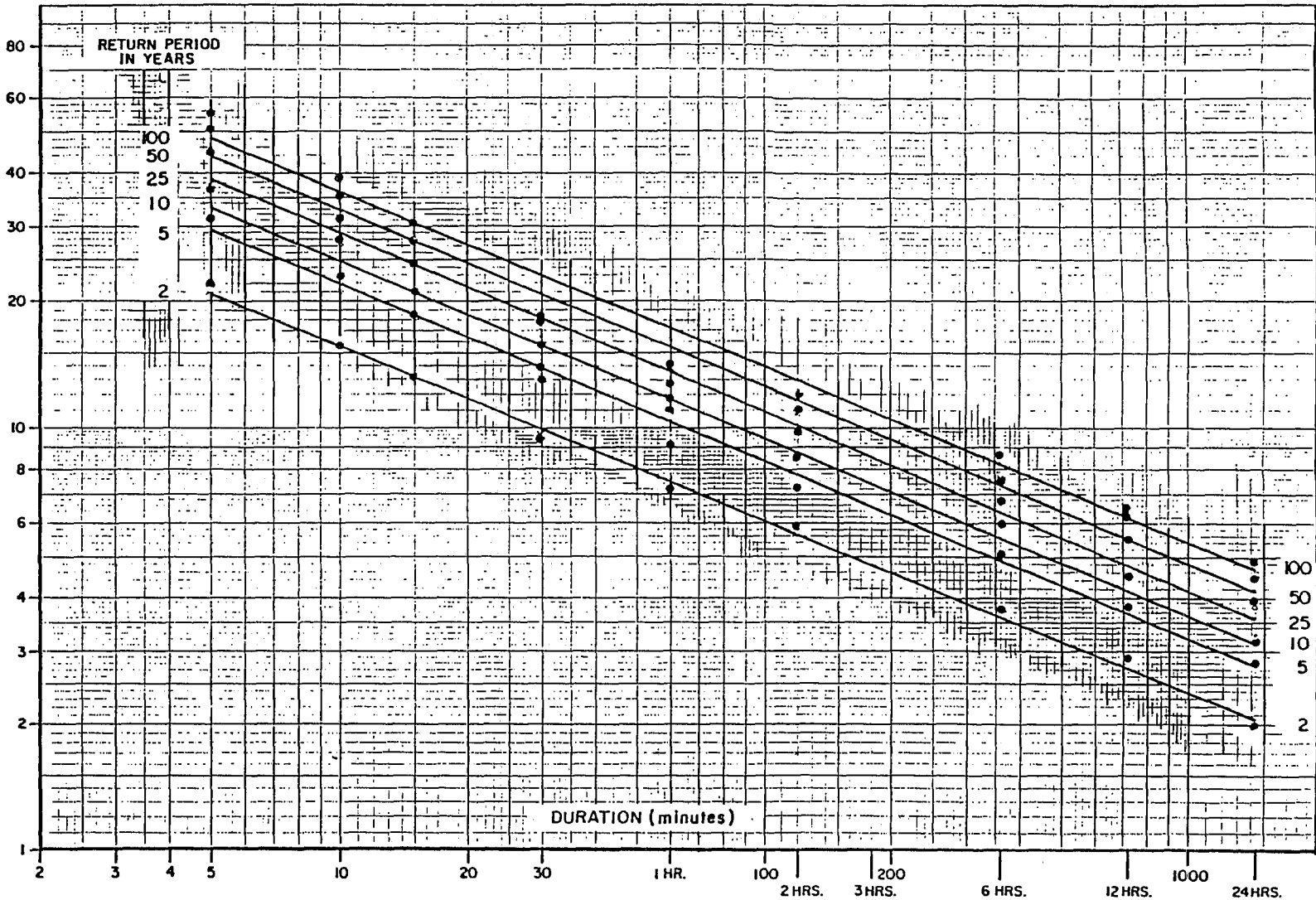

**SHORT DURATION RAINFALL - INTENSITY - FREQUENCY DATA
FOR REGIONAL CLIMATE DATA CENTRE • VICTORIA - GONZALES**
BASED ON RECORDING RAIN GAUGE DATA FOR THE PERIOD 1925-30, 1937-51, 1953-86 (54 YEARS)

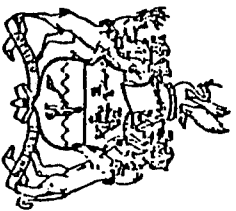

SD16

REGIONAL SPECIFICATION T 1

FOR UTILITY TRENCH EXCAVATION, BACKFILL AND CLEAN UP

1.0 Scope

- 1.01 This specification shall govern the excavation, backfilling and clean up for utility trenches within the Municipality. This relates to backfill above the pipe zone and below the finished surface.

2.0 Excavation

- 2.01 The trench shall be excavated to the required alignment, width, depth, and grade as shown on the approved design drawing.
- 2.02 Excavated material shall not be stockpiled on the roadway.
- 2.03 Where the maximum trench width is exceeded, reference must be made to the Consulting Engineer who shall obtain the approval of the Municipal Engineer before further construction may continue.
- 2.04 If the bottom of the trench is organic or other unsuitable material, the trench shall be over excavated to firm ground and backfilled with suitable compacted material for pipe support, unless otherwise specified by the Consulting Engineer.
- 2.05 Trench water must be removed.
- 2.06 All solid rock boulders and large stones shall be removed to provide a minimum clearance of 150 mm around the pipe.
- 2.07 Where an existing structure or underground installation may be affected by the works, it is the responsibility of the Consulting Engineer to inform the owner of such utility sufficiently in advance to enable the owner to specify what protective measures must be taken.

3.0 Backfill

- 3.01 Where a pipe or conduit is installed beneath an existing or foreseeable future pavement, sidewalk, driveway or gravel shoulder, the backfill shall be pitrun gravel or equal, compacted to a minimum 95% Standard Proctor Density, except for the top 300 mm which shall be 100%.
- 3.02 Suitable native materials may be used as backfill where the pipe or conduit is installed in non-travelled areas. Backfill in these cases shall be free of stones over 150 mm size, frozen material, organic, or other perishable or objectionable material that would prevent proper consolidation or which might cause subsequent settlement.

REGIONAL SPECIFICATION T 1

- 3.03 Controlled density backfill may be used in lieu of compacted gravel backfill. Controlled density or unshrinkable fill shall be manufactured and placed in accordance with Canadian Portland Cement Association publication CP004.01P.
- 3.04 Where it is required to replace topsoil it shall occupy the upper 300 mm of the trench and shall be mounded on top to allow for settlement. If the installation is under a developed lawn, the soil shall be fine raked during the appropriate season and sown with a top quality grass seed at the rate of 50 grams of seed per square metre and rolled.

4.0 Cleanup

- 4.01 Gravel filled trenches shall be maintained to within 25 mm of the original surface prior to final paving.
- 4.02 Patching cuts in existing pavement.
- a) Cuts must be hot mix paved within 3 days of backfilling.
 - b) If weather conditions do not permit hot-mix asphalt, cuts shall be paved within 3 days of backfilling using cold-mix asphalt and replaced as weather permits.
 - c) Where the excavation is on the shoulder or under the travelled portion of the street, the surface material shall be cut in neat straight lines at the edges of the trench by means of an asphalt cutting wheel, milling machine or pneumatic pavement breaker. Where the edges of any area requiring repaving extend outside the straight lines cut, further cuts shall be made so that the final patch will have a neat appearance.
 - d) Any area of pavement adjacent to the excavation which has become undermined or deformed due to excavation practices or blasting shall be removed and repaved as above.
 - e) The pavement of cuts which have settled shall be removed, the trench shall be recompacted and repaved.

5.0 Testing

- 5.01 The Consulting Engineer shall, at his direction, arrange for periodic compaction testing within the trench where trenches are over one metre deep. Test results shall be submitted to the Municipal Engineer.

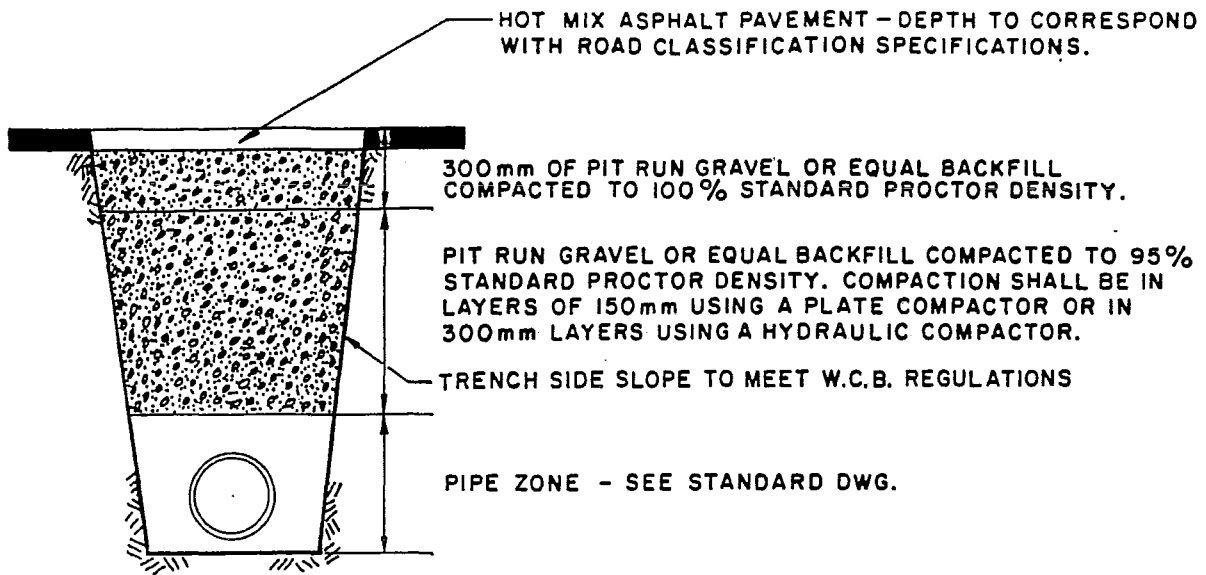

NOTE:

- 1 Unshrinkable fill may be used in lieu of compacted gravel backfill.
- 2 This specification shall include the travelled portion of the road and driveways or within 1.0m of the edge of the travelled road.
- 3 Within new road construction, the trench is to be backfilled up to 300mm of ground level with the remaining 300mm backfilled / compacted road gravel.

UNDER THE TRAVELLED PORTION OF THE ROAD AND DRIVEWAY

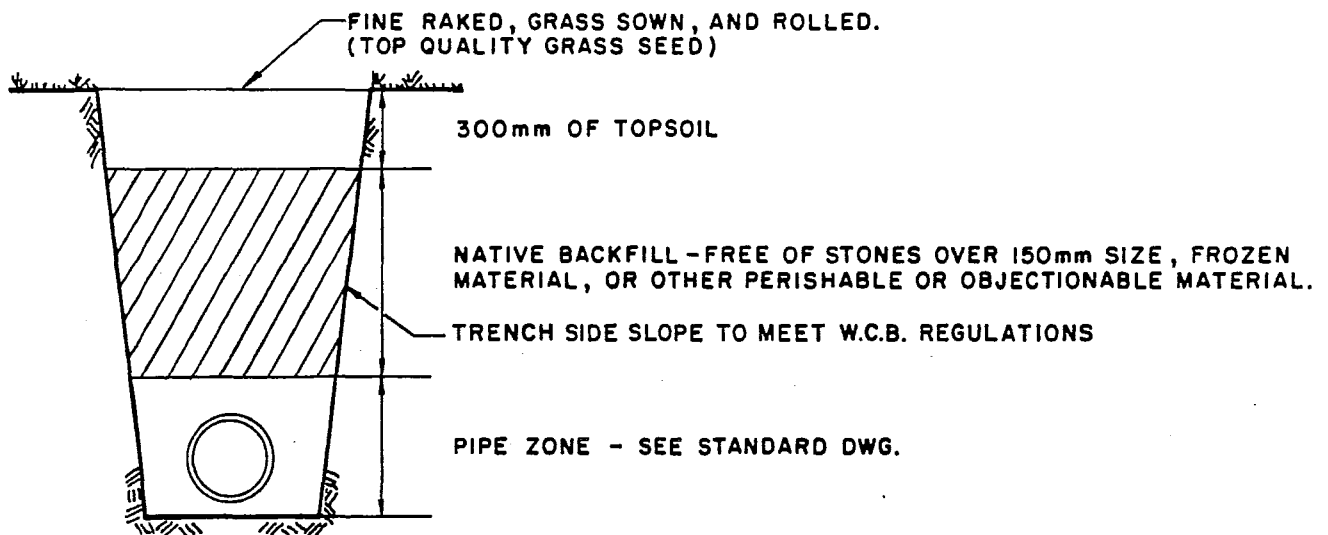

NON-TRAVELLED AREAS

DATE	REVISIONS	APPROVED
------	-----------	----------

REGIONAL MUNICIPAL SPECIFICATION

TRENCH CONDITIONS ABOVE THE PIPE ZONE



STD. DWG. N°

T 1